



NEW!

Introducing...



Fast-Fit

Aligns and Secures

Patent Application No. 1215466.2



**NEED
GLASS?**
Let Us Quote

FREE FIXINGS

TESTED TO BS6180

**SUPERIOR CORROSION
RESISTANCE WITH G316's'**













































Innovative Handrail Solutions

Fastec Handrail Systems



INFORMATION CONTENTS

Fast Fit	page 4
About Us & Philosophy	page 7
Superior Corrosion Resistance With G316's'	page 9
The Fastec Handrail System & Quality	page 10
Customer Care & Delivery	page 11
Enquiry Sheets	page 72
Safety Test Results	page 78
Care and Maintenance	page 82
Index	page 84

Glass	page 12	
Fittings	page 15	    
Tubes & Bars	page 39	    
Mirror Polished	page 41	    
Glass Clamps	page 45	    
Glass Connectors & Panel Holders	page 57	    
Wire-tec	page 61	    
Timber-tec	page 65	    
Accessories	page 68	    



FREE FIXINGS
with all fittings
See Page 71



TESTED TO
BS6180
See Page 78



Introducing...

Fast-Fit



The Fastec 'Fast-Fit' system has been developed to help installers by aligning and securing the fitting into the tube until the glue cures. With just a simple push and twist the Fast-Fit rubber sleeve slides into the tube firmly holding and aligning the fitting. This allows installers to move onto the next joint safe in the knowledge that the fitting will be held correctly in position without vibrating loose or misaligning.

The Perfect Fit

CENTRALISES AND ALIGNS

Once inserted the unique rubber sleeve compresses equally around the circumference compensating for any movement between the fittings and tube. This equal compression centralises the fitting with the tube ensuring a consistent alignment between the two parts.

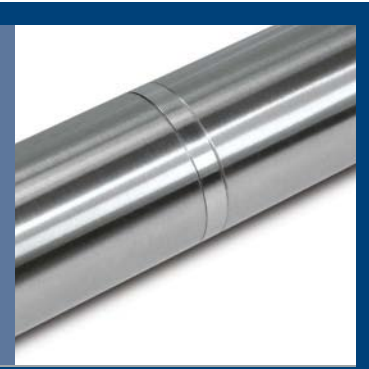

SECURES AND STABILISES

To help enable a secure and seamless fit for your joints Fast-Fit will securely hold the fitting in place whilst the glue is curing preventing gaps from forming through movement and vibration. By tightly securing the fitting to the tube allows the installer to move onto the next joint without the need for extra remedial works to hold the fitting and tube together whilst the glue cures.



SAVING TIME AND MONEY

The simple solution that the Fast-Fit system offers is based on the key principles of saving time and money for the installer. To help with this cost reduction the Fast-Fit range will be charged at no extra cost allowing installers all the benefits of the Fast-Fit system at the same competitive price.



QUICKER INSTALLATION TIMES

Having the benefit of aligning and securing each joint Fast-Fit allows installation times to be reduced by upto 20%. The Fast-Fit unique innovation means installers do not need to taking extra remedial work to secure the joints or wait until the glue cures before proceeding but can quickly progress from one joint to the next.



AVAILABLE FOR ALL GLUED INSERTS

The Fast-Fit system is available on all glued inserts for 48.3mm and 42.4mm diameter connectors, this means that the whole range has been incorporated giving the installer the benefit of the Fast-Fit system on all glued inserts.





about us

Fastec Handrail Systems specialises in the supply and delivery of off-the-shelf stainless steel modular handrail fittings.

We have designed and manufactured our Fastec modular handrail fittings to fulfil all your requirements.

Fastec Handrail Systems forms part of the Barrett Steel Ltd group. We operate from a purpose-designed 3100ft² warehouse and sales facility and hold extensive stocks within the UK, ensuring rapid next-day turnaround to service and meet all your requirements.

Our friendly sales advisors are here to help, offering sales assistance and technical support to ensure you receive the best levels of service and aftercare.

Fastec has established a reputation for outstanding customer service, total reliability, fast delivery and above all, premium quality products.

All our products are available off the shelf, ready for next-day delivery wherever you are in the UK. We will help you stay within your project's budget without compromising on quality, service or the aesthetic appearance of your completed installation.

And for your complete peace of mind, our products have been independently tested for safety.

philosophy

Creativity. Innovation. Technical Mastery

These are Fastec Handrail Systems watchwords. We are a progressive business, working in long-term partnerships with our customers to realise your project's full aesthetic and functional potential.

You can be sure we understand your business and the environment in which you operate. Our customers choose us because they know they can rely on our innovative approach and complete commitment to the success of a project.

We'll work closely with you to ensure your budgets and timescales are met sharing our judgement, expertise and problem solving skills to guarantee the best outcome for your project and your business.

We focus on your requirements because the end result is as important to us as it is to you. That's why we add value every step of the way whilst keeping you on schedule and within budget. We're more than happy to have a no-obligation discussion with you about your current and future plans.

Call us today – we are waiting to hear from you.



achieving a **superior** corrosion resistance with **G316's'**

Although stainless steel has an inherent corrosion resistance it cannot be called 'stain free'. In certain conditions it will stain and discolour.

To offer our customers a superior product and greater value for money, all G316 Fastec handrail fittings are manufactured using increased levels of 'Chromium', 'Molybdenum' & 'Nickel' which are above the maximum percentage stated for G316.

We have called this superior grade G316's' ('s' means superior). This higher grade offers substantially more corrosion resistance than standard G316, providing greater peace of mind, lower maintenance and less cleaning.

proven superiority

Sheffield Testing Laboratories Ltd have carried out stringent tests to compare the performance of G316 and G316's' under rigorous salt spray testing. The G316's' fitting outperformed the standard grade G316 fitting, showing no sign of staining over the same test period.

In addition to its unrivalled aesthetic appeal, Fastec G316's' products offer unmatched durability, long life and low maintenance, providing a robust, extra corrosion-resistant solution for a wide range of applications. Your installation will maintain its 'as new' appearance with minimal attention.

Our G316's' fittings offer superior corrosion resistance.





the **fastec** handrail system

Stainless steel is the architect's material of choice for a wide range of high-profile developments, from luxury residential apartments to shopping malls, nightclubs, shops, bars and restaurants.

Functionally practical and aesthetically pleasing, stainless steel handrailing, coupled with complementary glass and cable systems, is a hallmark of today's contemporary and minimalist designs. With its emphasis on simplicity, elegance and – crucially - low-maintenance, the Fastec range can accommodate all your requirements.

The benefits of the Fastec Handrail System are its versatility, modular nature and comprehensive range. In addition the whole system is designed with ease of manufacture, assembly and installation in mind.

Fastec lives up to its name: it can be fitted quickly and cleanly and above all no reworking is necessary.

quality

We aim to provide the best quality products within the market place. To ensure this, all the fittings within the Fastec range are manufactured and inspected to meet your high standards.

Fastec Handrail Systems has gained BS EN ISO9001: 2008 accreditation ensuring you benefit from exceptional product quality and service levels.

This accreditation guarantees that we conform to stringent quality control procedures. Ensuring we get it right first time, every time – so you will too.



RS24788

customer care

Our focus is your business.

Fastec is a customer-focused company. We take a meticulous approach to serving our customers, from initial enquiry through to delivery and after-sales services.

Providing the products and services our customers require is the key to our success. That's why we are proactive in anticipating the evolving needs of our customers.

Our highly experienced and knowledgeable technical experts will quickly understand the nature of your project and your precise requirements.

We are happy to deal with all your questions and enquiries and our experts will be able to guide you through our extensive range of products and the ordering process – whether you're working on a small domestic project or a substantial commercial or architectural development.

Above all, it is the level of personal service we provide, backed by our experience, knowledge and expertise, that ensures we always meet and frequently exceed our customers' expectations.

delivery

Once your order is placed, it will be promptly prepared for dispatch with the greatest care and attention to detail as part of our extensive quality control procedures.

We use only proven and reputable carriers so you can be confident that your order will arrive on time and in perfect condition ready for installation.

Orders received before 2.00pm will qualify for next-day delivery, and we can also arrange, on request, deliveries for specific time-slots such as before 10.30am, before noon, and Saturday morning.





GLASS

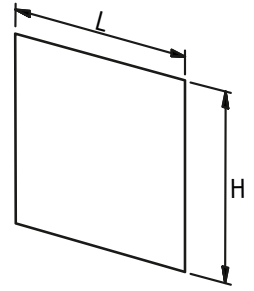
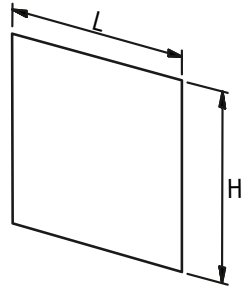

► **Toughened glass**

Toughened				
Class	mm	L	H	
12	12	TBC	TBC	1
15	15	TBC	TBC	1
19	19	TBC	TBC	1
25	25	TBC	TBC	1

► **Laminated glass**

Laminated				
Class		L	H	
12.76	6/6/2	TBC	TBC	1
13.52	6/6/4	TBC	TBC	1
16.76	8/8/2	TBC	TBC	1
17.52	8/8/4	TBC	TBC	1
20.76	10/10/2	TBC	TBC	1
21.52	10/10/4	TBC	TBC	1
25.52	12/12/4	TBC	TBC	1
31.52	15/15/4	TBC	TBC	1



ALL SHAPES. ALL SIZES
 MADE TO YOUR REQUIREMENTS
 AT COMPETITIVE PRICES

ONE STOP SHOP



FI



FITTINGS

Stem Connectors

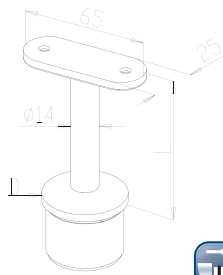

► 304 Model 0100

CODE	D	L	BOLT
34.0100.422.S	42.4 x 2.0	80	FF-12
34.0100.426.S	42.4 x 2.6	80	FF-12
34.0100.482.S	48.3 x 2.0	80	FF-12
34.0100.486.S	48.3 x 2.6	80	FF-12

► 316's' Model 0100

CODE	D	L	BOLT
36.0100.422.S	42.4 x 2.0	80	FF-13
36.0100.426.S	42.4 x 2.6	80	FF-13
36.0100.482.S	48.3 x 2.0	80	FF-13
36.0100.486.S	48.3 x 2.6	80	FF-13

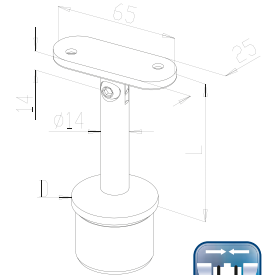

► 304 Model 0105

CODE	D	L	BOLT
34.0105.422.S	42.4 x 2.0	80	FF-12
34.0105.426.S	42.4 x 2.6	80	FF-12
34.0105.482.S	48.3 x 2.0	80	FF-12
34.0105.486.S	48.3 x 2.6	80	FF-12

► 316's' Model 0105

CODE	D	L	BOLT
36.0105.422.S	42.4 x 2.0	80	FF-13
36.0105.426.S	42.4 x 2.6	80	FF-13
36.0105.482.S	48.3 x 2.0	80	FF-13
36.0105.486.S	48.3 x 2.6	80	FF-13

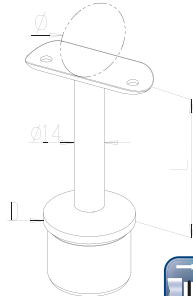
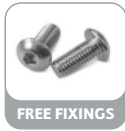

► 304 Model 0110

CODE	D	L	Ø	BOLT
34.0110.422.S	42.4 x 2.0	80	42.4	FF-10
34.0110.426.S	42.4 x 2.6	80	42.4	FF-10
34.0110.482.S	48.3 x 2.0	80	48.3	FF-10
34.0110.486.S	48.3 x 2.6	80	48.3	FF-10

► 304 Model 0111

CODE	D	L	Ø	BOLT
34.0111.422.S	42.4 x 2.0	80	48.3	FF-10
34.0111.426.S	42.4 x 2.6	80	48.3	FF-10
34.0111.486.S	48.3 x 2.6	80	42.4	FF-10

► 316's' Model 0110

CODE	D	L	Ø	BOLT
36.0110.422.S	42.4 x 2.0	80	42.4	FF-11
36.0110.426.S	42.4 x 2.6	80	42.4	FF-11
36.0110.482.S	48.3 x 2.0	80	48.3	FF-11
36.0110.486.S	48.3 x 2.6	80	48.3	FF-11

► 316's' Model 0111

CODE	D	L	Ø	BOLT
36.0111.422.S	42.4 x 2.0	80	48.3	FF-11
36.0111.426.S	42.4 x 2.6	80	48.3	FF-11
36.0111.486.S	48.3 x 2.6	80	42.4	FF-11

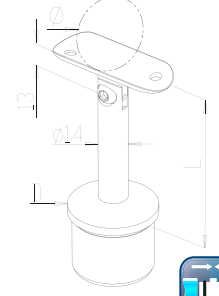
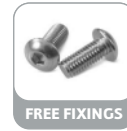

► 304 Model 0115

CODE	D	L	Ø	BOLT
34.0115.422.S	42.4 x 2.0	80	42.4	FF-10
34.0115.426.S	42.4 x 2.6	80	42.4	FF-10
34.0115.482.S	48.3 x 2.0	80	48.3	FF-10
34.0115.486.S	48.3 x 2.6	80	48.3	FF-10

► 304 Model 0116

CODE	D	L	Ø	BOLT
34.0116.422.S	42.4 x 2.0	80	48.3	FF-10
34.0116.426.S	42.4 x 2.6	80	48.3	FF-10
34.0116.486.S	48.3 x 2.6	80	42.4	FF-10

► 316's' Model 0115

CODE	D	L	Ø	BOLT
36.0115.422.S	42.4 x 2.0	80	42.4	FF-11
36.0115.426.S	42.4 x 2.6	80	42.4	FF-11
36.0115.482.S	48.3 x 2.0	80	48.3	FF-11
36.0115.486.S	48.3 x 2.6	80	48.3	FF-11

► 316's' Model 0116

CODE	D	L	Ø	BOLT
36.0116.422.S	42.4 x 2.0	80	48.3	FF-11
36.0116.426.S	42.4 x 2.6	80	48.3	FF-11
36.0116.486.S	48.3 x 2.6	80	42.4	FF-11

Stem Connectors

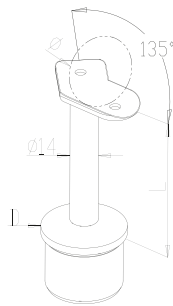
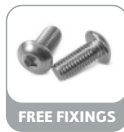

► 304 Model 0120

CODE	D	L	Ø	BOLT
34.0120.422.S	42.4 x 2.0	80	42.4	FF-10
34.0120.426.S	42.4 x 2.6	80	42.4	FF-10
34.0120.482.S	48.3 x 2.0	80	48.3	FF-10
34.0120.486.S	48.3 x 2.6	80	48.3	FF-10

► 304 Model 0121

CODE	D	L	Ø	BOLT
34.0121.422.S	42.4 x 2.0	80	48.3	FF-10
34.0121.426.S	42.4 x 2.6	80	48.3	FF-10
34.0121.486.S	48.3 x 2.6	80	42.4	FF-10

► 316's' Model 0120

CODE	D	L	Ø	BOLT
36.0120.422.S	42.4 x 2.0	80	42.4	FF-11
36.0120.426.S	42.4 x 2.6	80	42.4	FF-11
36.0120.482.S	48.3 x 2.0	80	48.3	FF-11
36.0120.486.S	48.3 x 2.6	80	48.3	FF-11

► 316's' Model 0121

CODE	D	L	Ø	BOLT
36.0121.422.S	42.4 x 2.0	80	48.3	FF-11
36.0121.426.S	42.4 x 2.6	80	48.3	FF-11
36.0121.486.S	48.3 x 2.6	80	42.4	FF-11

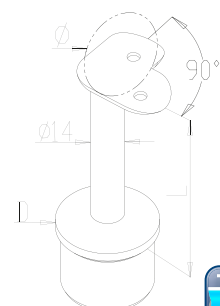
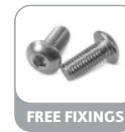

► 304 Model 0130

CODE	D	L	Ø	BOLT
34.0130.422.S	42.4 x 2.0	80	42.4	FF-10
34.0130.426.S	42.4 x 2.6	80	42.4	FF-10
34.0130.482.S	48.3 x 2.0	80	48.3	FF-10
34.0130.486.S	48.3 x 2.6	80	48.3	FF-10

► 304 Model 0131

CODE	D	L	Ø	BOLT
34.0131.422.S	42.4 x 2.0	80	48.3	FF-10
34.0131.426.S	42.4 x 2.6	80	48.3	FF-10
34.0131.486.S	48.3 x 2.6	80	42.4	FF-10

► 316's' Model 0130

CODE	D	L	Ø	BOLT
36.0130.422.S	42.4 x 2.0	80	42.4	FF-11
36.0130.426.S	42.4 x 2.6	80	42.4	FF-11
36.0130.482.S	48.3 x 2.0	80	48.3	FF-11
36.0130.486.S	48.3 x 2.6	80	48.3	FF-11

► 316's' Model 0131

CODE	D	L	Ø	BOLT
36.0131.422.S	42.4 x 2.0	80	48.3	FF-11
36.0131.426.S	42.4 x 2.6	80	48.3	FF-11
36.0131.486.S	48.3 x 2.6	80	42.4	FF-11

F ACCESSORIES



PAGE 69

Glue
50 ml
10.9010.000.A

F INFO



Stem and Saddles

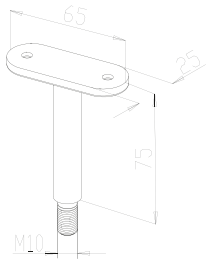

► 304 Model 0200

CODE	BOLT
34.0200.000.S	FF-12

► 316's' Model 0200

CODE	BOLT
36.0200.000.S	FF-13

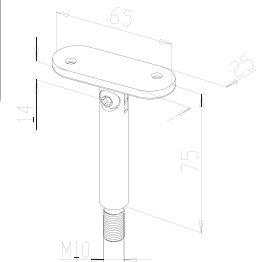

► 304 Model 0205

CODE	BOLT
34.0205.000.S	FF-12

► 316's' Model 0205

CODE	BOLT
36.0205.000.S	FF-13

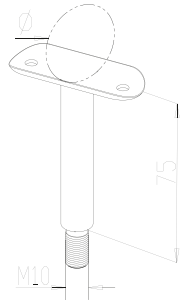
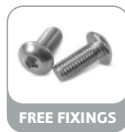

► 304 Model 0200

CODE	Ø	BOLT
34.0200.420.S	42.4	FF-10
34.0200.480.S	48.3	FF-10

► 316's' Model 0200

CODE	Ø	BOLT
36.0200.420.S	42.4	FF-11
36.0200.480.S	48.3	FF-11

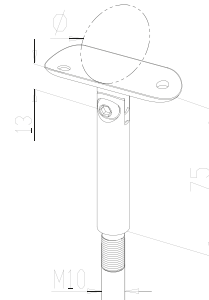
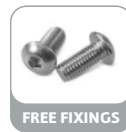

► 304 Model 0205

CODE	Ø	BOLT
34.0205.420.S	42.4	FF-10
34.0205.480.S	48.3	FF-10

► 316's' Model 0205

CODE	Ø	BOLT
36.0205.420.S	42.4	FF-11
36.0205.480.S	48.3	FF-11

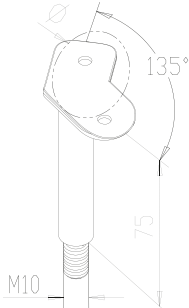
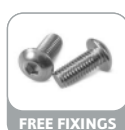

► 304 Model 0210

CODE	Ø	BOLT
34.0210.420.S	42.4	FF-10
34.0210.480.S	48.3	FF-10

► 316's' Model 0210

CODE	Ø	BOLT
36.0210.420.S	42.4	FF-11
36.0210.480.S	48.3	FF-11

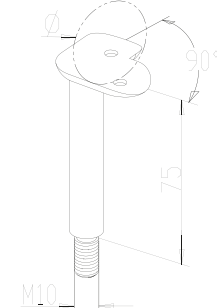
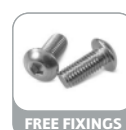

► 304 Model 0220

CODE	Ø	BOLT
34.0220.420.S	42.4	FF-10
34.0220.480.S	48.3	FF-10

► 316's' Model 0220

CODE	Ø	BOLT
36.0220.420.S	42.4	FF-11
36.0220.480.S	48.3	FF-11

Handrail Saddle/Stems

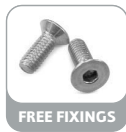

► 304 Model 0300

CODE	BOLT
34.0300.000.S	FF-12

► 316's' Model 0300

CODE	BOLT
36.0300.000.S	FF-11

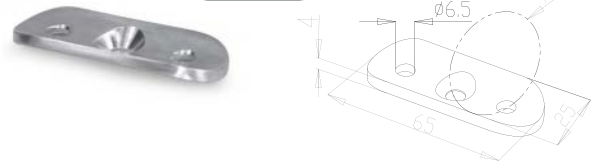
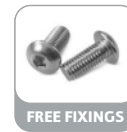

► 304 Model 0300

CODE	Ø	BOLT
34.0300.420.S	42.4	FF-10
34.0300.480.S	48.3	FF-10

► 316's' Model 0300

CODE	Ø	BOLT
36.0300.420.S	42.4	FF-11
36.0300.480.S	48.3	FF-11

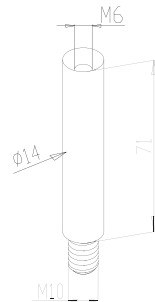
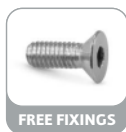

► 304 Model 0310

CODE	BOLT
34.0310.000.S	FF-50

► 316's' Model 0310

CODE	BOLT
36.0310.000.S	FF-51

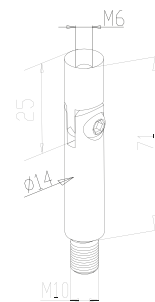
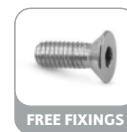

► 304 Model 0315

CODE	BOLT
34.0315.000.S	FF-50

► 316's' Model 0315

CODE	BOLT
36.0315.000.S	FF-51

F ACCESSORIES



PAGE 69

Stainless Steel
Cleaner
500 ml
10.9020.000.A

F ACCESSORIES



PAGE 69

Stain Remover
500 ml
10.9030.000.A

F INFO



Handrail Brackets - Post Fix



► 304 Model 0400

CODE	BOLT
34.0400.000.S	FF-12 / FF-21

► 316's' Model 0400

CODE	BOLT
36.0400.000.S	FF-13 / FF-22

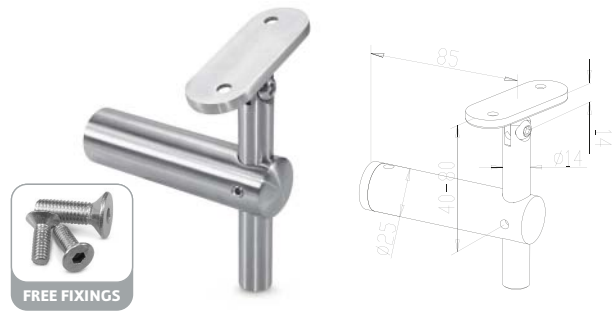

► 304 Model 0405

CODE	BOLT
34.0405.000.S	FF-12 / FF-2

► 316's' Model 0405

CODE	BOLT
36.0405.000.S	FF-13 / FF-22



► 304 Model 0400

CODE	Ø	BOLT
34.0400.420.S	42.4	FF-10 / FF-21
34.0400.480.S	48.3	FF-10 / FF-21

► 316's' Model 0400

CODE	Ø	BOLT
36.0400.420.S	42.4	FF-11 / FF-22
36.0400.480.S	48.3	FF-11 / FF-22



► 304 Model 0405

CODE	Ø	BOLT
34.0405.420.S	42.4	FF-10 / FF-21
34.0405.480.S	48.3	FF-10 / FF-21

► 316's' Model 0405

CODE	Ø	BOLT
36.0405.420.S	42.4	FF-11 / FF-22
36.0405.480.S	48.3	FF-11 / FF-22



E INFO

'Part M' Requirement

Diagram 7 Handrail design

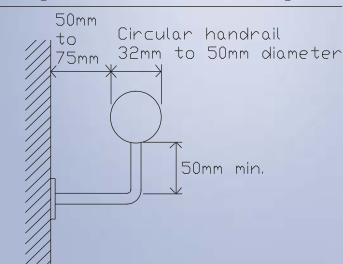

E INFO



Handrail Brackets - Post Fix



► 304 Model 0410

CODE	D	BOLT
34.0410.420.S	42.4	FF-12 / FF-21
34.0410.480.S	48.3	FF-12 / FF-21

► 316's' Model 0410

CODE	D	BOLT
36.0410.420.S	42.4	FF-13 / FF-22
36.0410.480.S	48.3	FF-13 / FF-22



► 304 Model 0415

CODE	D	BOLT
34.0415.420.S	42.4	FF-12 / FF-21
34.0415.480.S	48.3	FF-12 / FF-21

► 316's' Model 0415

CODE	D	BOLT
36.0415.420.S	42.4	FF-13 / FF-22
36.0415.480.S	48.3	FF-13 / FF-22



► 304 Model 0420/0421

CODE	D	Ø	BOLT
34.0420.420.S	42.4	42.4	FF-10 / FF-21
34.0420.480.S	48.3	48.3	FF-10 / FF-21
34.0421.420.S	42.4	48.3	FF-10 / FF-21

► 316's' Model 0420/0421

CODE	D	Ø	BOLT
36.0420.420.S	42.4	42.4	FF-11 / FF-22
36.0420.480.S	48.3	48.3	FF-11 / FF-22
36.0421.420.S	42.4	48.3	FF-11 / FF-22



► 304 Model 0425/0426

CODE	D	Ø	BOLT
34.0425.420.S	42.4	42.4	FF-10 / FF-21
34.0425.480.S	48.3	48.3	FF-10 / FF-21
34.0426.420.S	42.4	48.3	FF-10 / FF-21

► 316's' Model 0425/0426

CODE	D	Ø	BOLT
36.0425.420.S	42.4	42.4	FF-11 / FF-22
36.0425.480.S	48.3	48.3	FF-11 / FF-22
36.0426.420.S	42.4	48.3	FF-11 / FF-22



INFO



INFO

'Part M' Requirement

Diagram 7 Handrail design

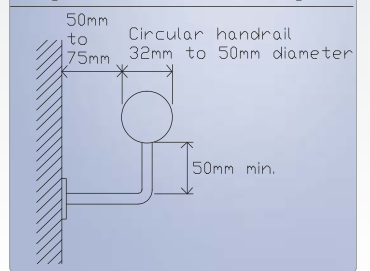

Handrail Brackets - Wall Fix



► 304 Model 0430

CODE	BOLT
34.0430.000.S	FF-12

► 316's' Model 0430

CODE	BOLT
36.0430.000.S	FF-13

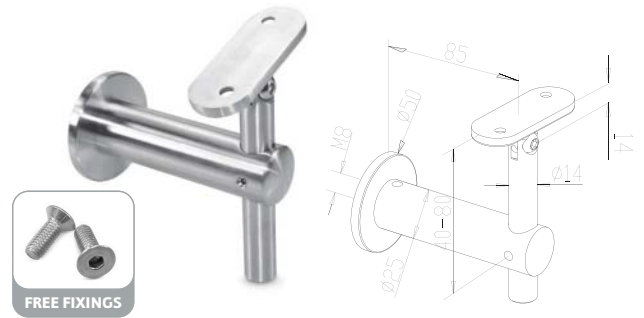

► 304 Model 0435

CODE	BOLT
34.0435.000.S	FF-12

► 316's' Model 0435

CODE	BOLT
36.0435.000.S	FF-13



► 304 Model 0430

CODE	Ø	BOLT
34.0430.420.S	42.4	FF-10
34.0430.480.S	48.3	FF-10

► 316's' Model 0430

CODE	Ø	BOLT
36.0430.420.S	42.4	FF-11
36.0430.480.S	48.3	FF-11



► 304 Model 0435

CODE	Ø	BOLT
34.0435.420.S	42.4	FF-10
34.0435.480.S	48.3	FF-10

► 316's' Model 0435

CODE	Ø	BOLT
36.0435.420.S	42.4	FF-11
36.0435.480.S	48.3	FF-11



E INFO

'Part M' Requirement

Diagram 7 Handrail design

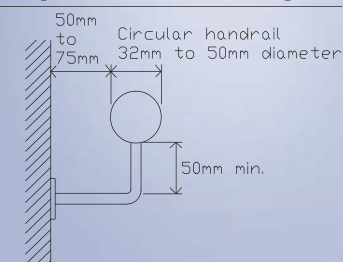

E INFO



Handrail Brackets - Glass Fix

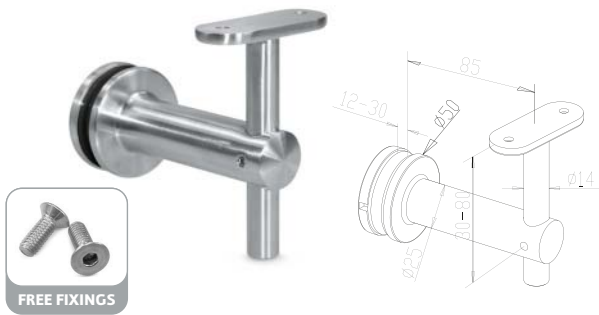

► 304 Model 0440

CODE	BOLT
34.0440.000.S	FF-12

► 316's' Model 0440

CODE	BOLT
36.0440.000.S	FF-13

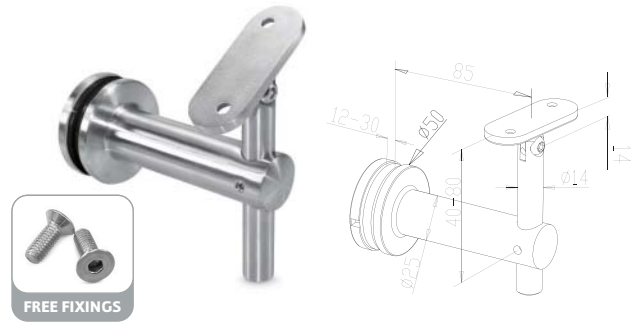

► 304 Model 0445

CODE	BOLT
34.0445.000.S	FF-12

► 316's' Model 0445

CODE	BOLT
36.0445.000.S	FF-13

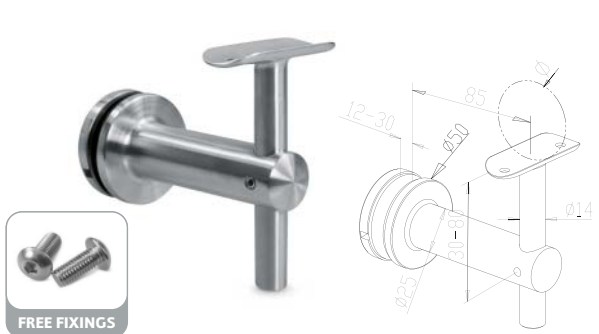

► 304 Model 0440

CODE	Ø	BOLT
34.0440.420.S	42.4	FF-10
34.0440.480.S	48.3	FF-10

► 316's' Model 0440

CODE	Ø	BOLT
36.0440.420.S	42.4	FF-11
36.0440.480.S	48.3	FF-11

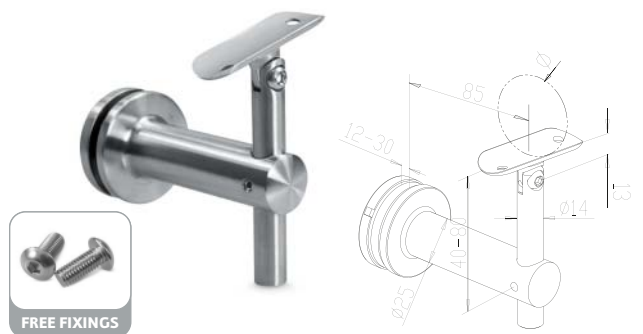

► 304 Model 0445

CODE	Ø	BOLT
34.0445.420.S	42.4	FF-10
34.0445.480.S	48.3	FF-10

► 316's' Model 0445

CODE	Ø	BOLT
36.0445.420.S	42.4	FF-11
36.0445.480.S	48.3	FF-11



INFO

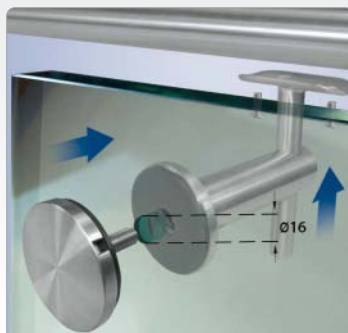

INFO

'Part M' Requirement

Diagram 7 Handrail design

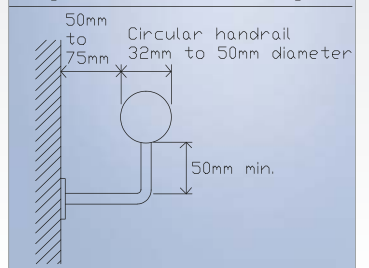

Handrail Brackets - Wall Fix

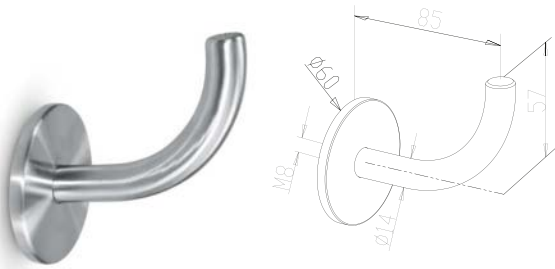

► **304 Model 0510**

CODE
34.0510.000.S

► **316's' Model 0510**

CODE
36.0510.000.S

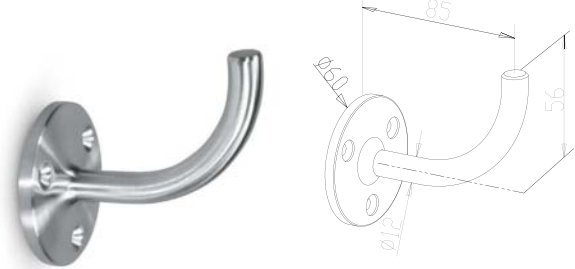

► **304 Model 0520**

CODE
34.0520.000.S

► **316's' Model 0520**

CODE
36.0520.000.S

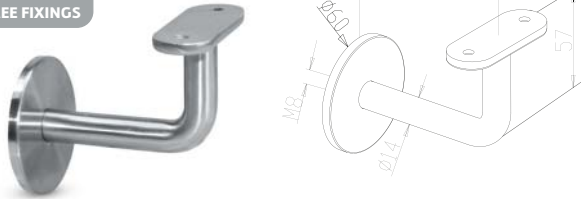
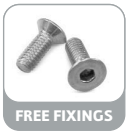

► **304 Model 0511**

CODE	BOLT
34.0511.000.S	FF-12

► **316's' Model 0511**

CODE	BOLT
36.0511.000.S	FF-13

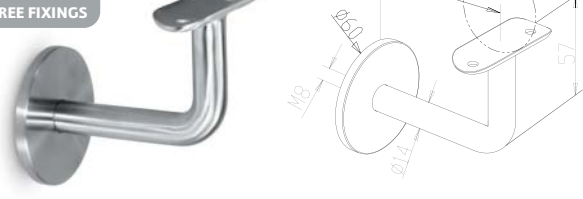
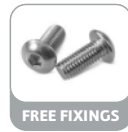

► **304 Model 0511**

CODE	Ø	BOLT
34.0511.420.S	42.4	FF-10
34.0511.480.S	48.3	FF-10

► **316's' Model 0511**

CODE	Ø	BOLT
36.0511.420.S	42.4	FF-11
36.0511.480.S	48.3	FF-11

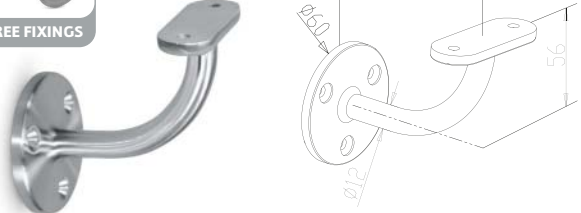
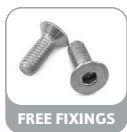

► **304 Model 0521**

CODE	BOLT
34.0521.000.S	FF-12

► **316's' Model 0521**

CODE	BOLT
36.0521.000.S	FF-13

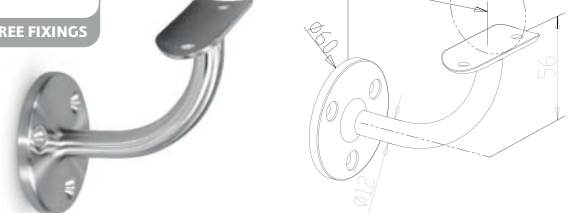
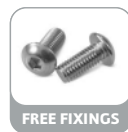

► **304 Model 0521**

CODE	Ø	BOLT
34.0521.420.S	42.4	FF-10
34.0521.480.S	48.3	FF-10

► **316's' Model 0521**

CODE	Ø	BOLT
36.0521.420.S	42.4	FF-11
36.0521.480.S	48.3	FF-11



Handrail Supports

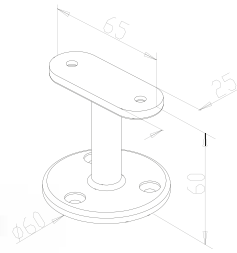

► **304 Model 0530**

CODE	BOLT
34.0530.000.S	FF-12

► **316's' Model 0530**

CODE	BOLT
36.0530.000.S	FF-13

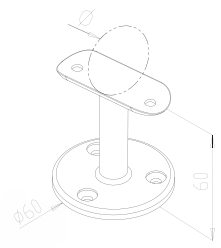
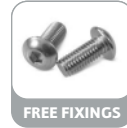

► **304 Model 0530**

CODE	Ø	BOLT
34.0530.420.S	42.4	FF-10
34.0530.480.S	48.3	FF-10

► **316's' Model 0530**

CODE	Ø	BOLT
36.0530.420.S	42.4	FF-11
36.0530.480.S	48.3	FF-11

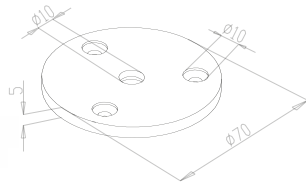
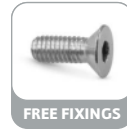

► **304 Model 0540**

CODE	BOLT
34.0540.070.S	FF-48

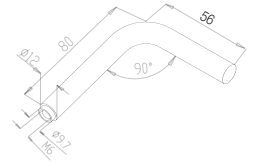
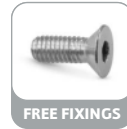

► **304 Model 0541**

CODE	BOLT
34.0541.000.S	FF-48

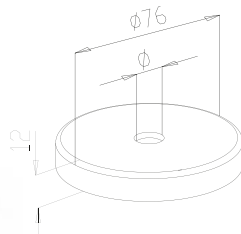

► **304 Model 0542**

CODE	Ø
34.0542.012.S	12



E INFO

'Part M' Requirement

Diagram 7 Handrail design

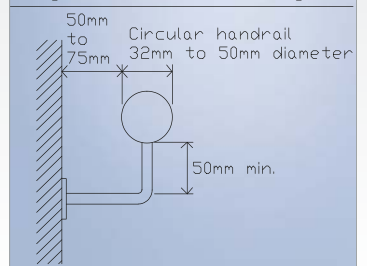

Elbows

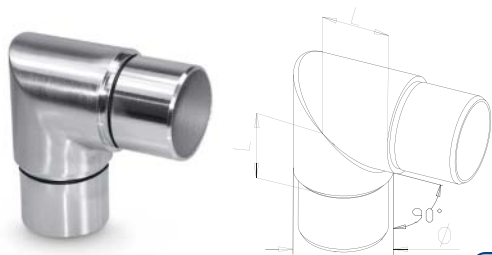

► 304 Model 0600

CODE	L	Ø
34.0600.422.S	30	42.4 x 2.0
34.0600.426.S	30	42.4 x 2.6
34.0600.482.S	35	48.3 x 2.0
34.0600.486.S	35	48.3 x 2.6

► 316's' Model 0600

CODE	L	Ø
36.0600.422.S	30	42.4 x 2.0
36.0600.426.S	30	42.4 x 2.6
36.0600.482.S	35	48.3 x 2.0
36.0600.486.S	35	48.3 x 2.6



► 304 Model 0610

CODE	L	Ø
34.0610.422.S	30	42.4 x 2.0
34.0610.426.S	30	42.4 x 2.6
34.0610.482.S	35	48.3 x 2.0
34.0610.486.S	35	48.3 x 2.6

► 316's' Model 0610

CODE	L	Ø
36.0610.422.S	30	42.4 x 2.0
36.0610.426.S	30	42.4 x 2.6
36.0610.482.S	35	48.3 x 2.0
36.0610.486.S	35	48.3 x 2.6

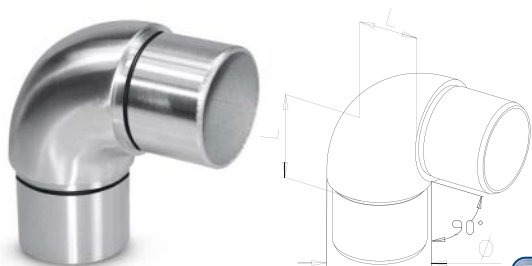

► 304 Model 0620

CODE	L	Ø
34.0620.422.S	30	42.4 x 2.0
34.0620.426.S	30	42.4 x 2.6
34.0620.482.S	35	48.3 x 2.0
34.0620.486.S	35	48.3 x 2.6

► 316's' Model 0620

CODE	L	Ø
36.0620.422.S	30	42.4 x 2.0
36.0620.426.S	30	42.4 x 2.6
36.0620.482.S	35	48.3 x 2.0
36.0620.486.S	35	48.3 x 2.6

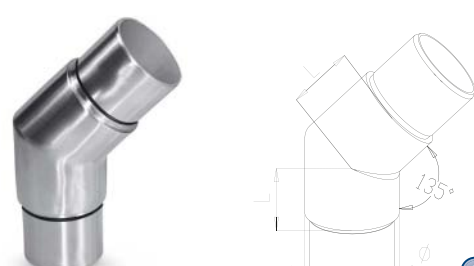

► 304 Model 0630

CODE	L	Ø
34.0630.422.S	30	42.4 x 2.0
34.0630.426.S	30	42.4 x 2.6
34.0630.482.S	35	48.3 x 2.0
34.0630.486.S	35	48.3 x 2.6

► 316's' Model 0630

CODE	L	Ø
36.0630.422.S	30	42.4 x 2.0
36.0630.426.S	30	42.4 x 2.6
36.0630.482.S	35	48.3 x 2.0
36.0630.486.S	35	48.3 x 2.6

F INFO



F ACCESSORIES



PAGE 69

Glue
50 ml
10.9010.000.A

Elbows

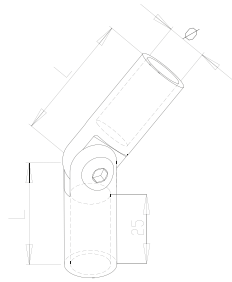

► 304 Model 0640

CODE	L	Ø
34.0640.012.S	35	12

► 316's' Model 0640

CODE	L	Ø
36.0640.012.S	35	12

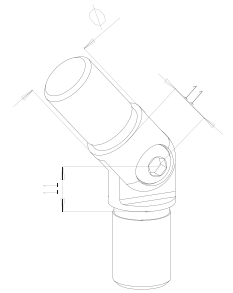

► 304 Model 0640

CODE	Ø
34.0640.016.S	16 x 1.0

► 316's' Model 0640

CODE	Ø
36.0640.016.S	16.0 x 1.0

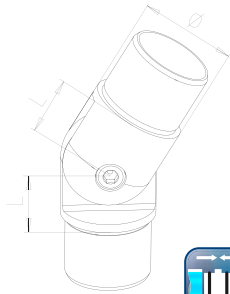

► 304 Model 0640

CODE	L	Ø
34.0640.422.S	27	42.4 x 2.0
34.0640.426.S	27	42.4 x 2.6
34.0640.482.S	30	48.3 x 2.0
34.0640.486.S	30	48.3 x 2.6

► 316's' Model 0640

CODE	L	Ø
36.0640.422.S	27	42.4 x 2.0
36.0640.426.S	27	42.4 x 2.6
36.0640.482.S	30	48.3 x 2.0
36.0640.486.S	30	48.3 x 2.6

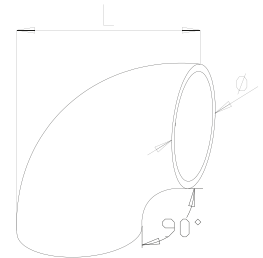

► 304 Model 0650

CODE	L	Ø
34.0650.420.S	65	42.4
34.0650.480.S	75	48.3

► 316's' Model 0650

CODE	L	Ø
36.0650.420.S	65	42.4
36.0650.480.S	75	48.3

F ACCESSORIES



PAGE 69

Stainless Steel
Cleaner
500 ml
10.9020.000.A

F ACCESSORIES



PAGE 69

Stain Remover
500 ml
10.9030.000.A

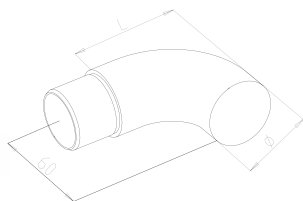

► 304 Model 0660

CODE	L	Ø
34.0660.422.S	80	42.4 x 2.0
34.0660.426.S	80	42.4 x 2.6
34.0660.482.S	85	48.3 x 2.0
34.0660.486.S	85	48.3 x 2.6

► 316's' Model 0660

CODE	L	Ø
36.0660.422.S	80	42.4 x 2.0
36.0660.426.S	80	42.4 x 2.6
36.0660.482.S	85	48.3 x 2.0
36.0660.486.S	85	48.3 x 2.6

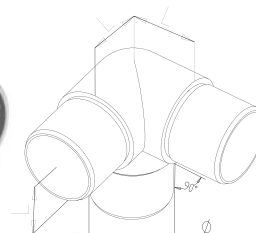

► 304 Model 0700

CODE	L	Ø
34.0700.422.S	30	42.4 x 2.0
34.0700.426.S	30	42.4 x 2.6
34.0700.482.S	35	48.3 x 2.0
34.0700.486.S	35	48.3 x 2.6

► 316's' Model 0700

CODE	L	Ø
36.0700.422.S	30	42.4 x 2.0
36.0700.426.S	30	42.4 x 2.6
36.0700.482.S	35	48.3 x 2.0
36.0700.486.S	35	48.3 x 2.6

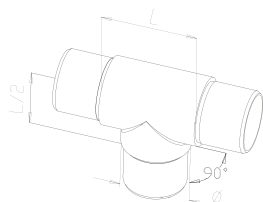

► 304 Model 0710

CODE	L	Ø
34.0710.422.S	60	42.4 x 2.0
34.0710.426.S	60	42.4 x 2.6
34.0710.482.S	70	48.3 x 2.0
34.0710.486.S	70	48.3 x 2.6

► 316's' Model 0710

CODE	L	Ø
36.0710.422.S	60	42.4 x 2.0
36.0710.426.S	60	42.4 x 2.6
36.0710.482.S	70	48.3 x 2.0
36.0710.486.S	70	48.3 x 2.6

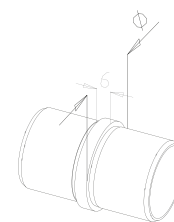

► 304 Model 0720

CODE	Ø
34.0720.422.S	42.4 x 2.0
34.0720.426.S	42.4 x 2.6
34.0720.482.S	48.3 x 2.0
34.0720.486.S	48.3 x 2.6

► 316's' Model 0720

CODE	Ø
36.0720.422.S	42.4 x 2.0
36.0720.426.S	42.4 x 2.6
36.0720.482.S	48.3 x 2.0
36.0720.486.S	48.3 x 2.6

E INFO



Connectors

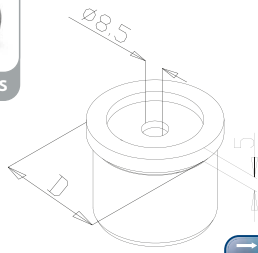

► 304 Model 0730

CODE	D	BOLT
34.0730.422.S	42.4 x 2.0	FF-45
34.0730.426.S	42.4 x 2.6	FF-45
34.0730.482.S	48.3 x 2.0	FF-45
34.0730.486.S	48.3 x 2.6	FF-45

► 316's' Model 0730

CODE	D	BOLT
36.0730.422.S	42.4 x 2.0	FF-46
36.0730.426.S	42.4 x 2.6	FF-46
36.0730.482.S	48.3 x 2.0	FF-46
36.0730.486.S	48.3 x 2.6	FF-46

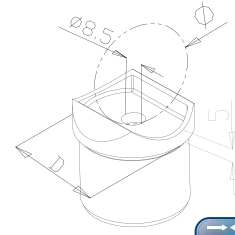

► 304 Model 0731/0732

CODE	D	Ø	BOLT
34.0731.422.S	42.4 x 2.0	42.4	FF-45
34.0731.426.S	42.4 x 2.6	42.4	FF-45
34.0731.482.S	48.3 x 2.0	48.3	FF-45
34.0731.486.S	48.3 x 2.6	48.3	FF-45
34.0732.422.S	42.4 x 2.0	48.3	FF-45
34.0732.426.S	42.4 x 2.6	48.3	FF-45

► 316's' Model 0731/0732

CODE	D	Ø	BOLT
36.0731.422.S	42.4 x 2.0	42.4	FF-46
36.0731.426.S	42.4 x 2.6	42.4	FF-46
36.0731.482.S	48.3 x 2.0	48.3	FF-46
36.0731.486.S	48.3 x 2.6	48.3	FF-46
36.0732.422.S	42.4 x 2.0	48.3	FF-46
36.0732.426.S	42.4 x 2.6	48.3	FF-46

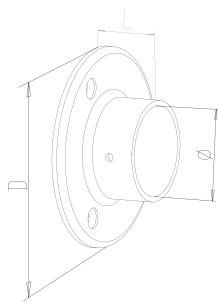

► 304 Model 0740

CODE	D	L	Ø	BOLT
34.0740.420.S	95	30	42.4	FF-6
34.0740.480.S	100	35	48.3	FF-6

► 316's' Model 0740

CODE	D	L	Ø	BOLT
36.0740.420.S	95	30	42.4	FF-7
36.0740.480.S	100	35	48.3	FF-7

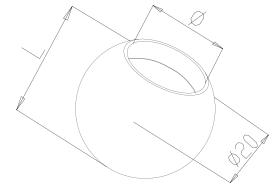

► 304 Model 0750

CODE	L	Ø
34.0750.012.S	17.5	12

► 316's' Model 0750

CODE	L	Ø
36.0750.012.S	17.5	12

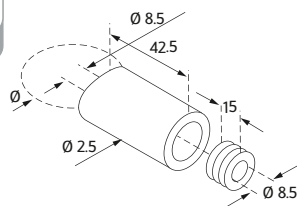

► 304 Model 0760

CODE	Ø	BOLT
34.0760.420.S	42.4	FF-29

► 316's' Model 0760

CODE	Ø	BOLT
36.0760.420.S	42.4	FF-30

E INFO



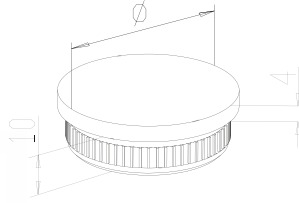

► 304 Model 0800

CODE	Ø
34.0800.422.S	42.4 x 2.0
34.0800.426.S	42.4 x 2.6
34.0800.482.S	48.3 x 2.0
34.0800.486.S	48.3 x 2.6

► 316's' Model 0800

CODE	Ø
36.0800.422.S	42.4 x 2.0
36.0800.426.S	42.4 x 2.6
36.0800.482.S	48.3 x 2.0
36.0800.486.S	48.3 x 2.6

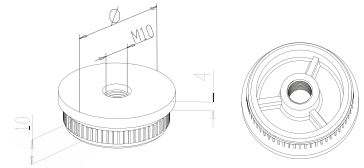

► 304 Model 0801

CODE	Ø
34.0801.422.S	42.4 x 2.0
34.0801.426.S	42.4 x 2.6
34.0801.482.S	48.3 x 2.0
34.0801.486.S	48.3 x 2.6

► 316's' Model 0801

CODE	Ø
36.0801.422.S	42.4 x 2.0
36.0801.426.S	42.4 x 2.6
36.0801.482.S	48.3 x 2.0
36.0801.486.S	48.3 x 2.6

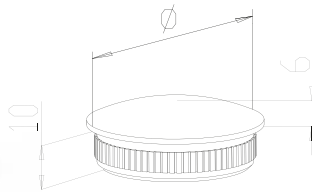

► 304 Model 0810

CODE	Ø
34.0810.422.S	42.4 x 2.0
34.0810.426.S	42.4 x 2.6
34.0810.482.S	48.3 x 2.0
34.0810.486.S	48.3 x 2.6

► 316's' Model 0810

CODE	Ø
36.0810.422.S	42.4 x 2.0
36.0810.426.S	42.4 x 2.6
36.0810.482.S	48.3 x 2.0
36.0810.486.S	48.3 x 2.6

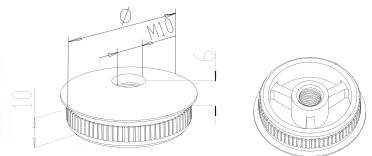

► 304 Model 0811

CODE	Ø
34.0811.422.S	42.4 x 2.0
34.0811.426.S	42.4 x 2.6
34.0811.482.S	48.3 x 2.0
34.0811.486.S	48.3 x 2.6

► 316's' Model 0811

CODE	Ø
36.0811.422.S	42.4 x 2.0
36.0811.426.S	42.4 x 2.6
36.0811.482.S	48.3 x 2.0
36.0811.486.S	48.3 x 2.6

F INFO

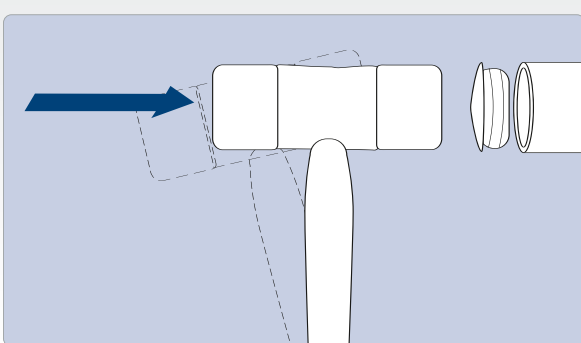

F ACCESSORIES



PAGE 69

Stain Remover
500 ml
10.9030.000.A

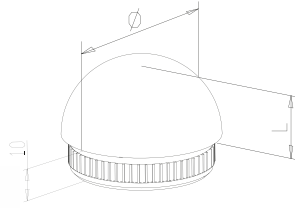

► 304 Model 0820

CODE	L	Ø
34.0820.422.S	21	42.4 x 2.0
34.0820.426.S	21	42.4 x 2.6
34.0820.482.S	24	48.3 x 2.0
34.0820.486.S	24	48.3 x 2.6

► 316's' Model 0820

CODE	L	Ø
36.0820.422.S	21	42.4 x 2.0
36.0820.426.S	21	42.4 x 2.6
36.0820.482.S	24	48.3 x 2.0
36.0820.486.S	24	48.3 x 2.6

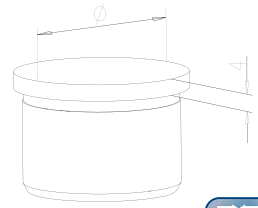

► 304 Model 0850

CODE	Ø
34.0850.422.S	42.4 x 2.0
34.0850.426.S	42.4 x 2.6
34.0850.482.S	48.3 x 2.0
34.0850.486.S	48.3 x 2.6

► 316's' Model 0850

CODE	Ø
36.0850.422.S	42.4 x 2.0
36.0850.426.S	42.4 x 2.6
36.0850.482.S	48.3 x 2.0
36.0850.486.S	48.3 x 2.6

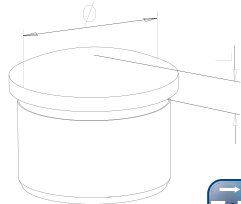

► 304 Model 0860

CODE	L	Ø
34.0860.016.S	4	16 x 1.0
34.0860.422.S	9	42.4 x 2.0
34.0860.426.S	9	42.4 x 2.6
34.0860.482.S	10	48.3 x 2.0
34.0860.486.S	10	48.3 x 2.6

► 316's' Model 0860

CODE	L	Ø
36.0860.422.S	9	42.4 x 2.0
36.0860.426.S	9	42.4 x 2.6
36.0860.482.S	10	48.3 x 2.0
36.0860.486.S	10	48.3 x 2.6

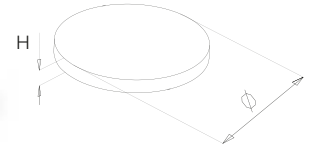

► 304 Model 0870

CODE	H	Ø
34.0870.042.S	4	42.4
34.0870.048.S	4	48.3
34.0870.050.S	4	50
34.0870.100.S	6	100

F ACCESSORIES



PAGE 69

Glue
50 ml
10.9010.000.A

F ACCESSORIES



PAGE 69

Stainless Steel
Cleaner
500 ml
10.9020.000.A

Side Fix Brackets

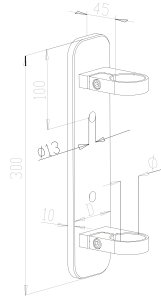

► 304 Model 1000

CODE	D	Ø
34.1000.420.S	70	42.4
34.1000.480.S	70	48.3

► 316's' Model 1000

CODE	D	Ø
36.1000.420.S	70	42.4
36.1000.480.S	70	48.3

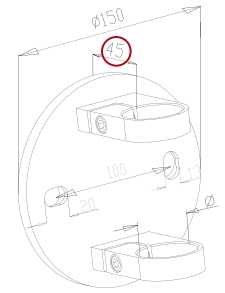

► 304 Model 1010

CODE	Ø
34.1010.420.S	42.4
34.1010.480.S	48.3

► 316's' Model 1010

CODE	Ø
36.1010.420.S	42.4
36.1010.480.S	48.3

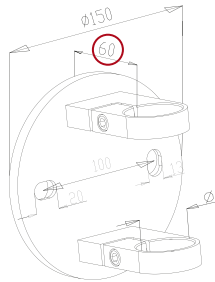

► 304 Model 1020

CODE	Ø
34.1020.420.S	42.4
34.1020.480.S	48.3

► 316's' Model 1020

CODE	Ø
36.1020.420.S	42.4
36.1020.480.S	48.3

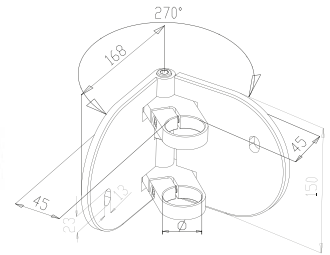

► 304 Model 1030

CODE	Ø
34.1030.420.S	42.4
34.1030.480.S	48.3

► 316's' Model 1030

CODE	Ø
36.1030.420.S	42.4
36.1030.480.S	48.3

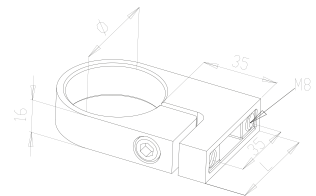

► 304 Model 1040

CODE	Ø	L
34.1040.420.S	42.4	50
34.1040.480.S	48.3	55

► 316's' Model 1040

CODE	Ø	L
36.1040.420.S	42.4	50
36.1040.480.S	48.3	55

E INFO



Welded Bases/Posts

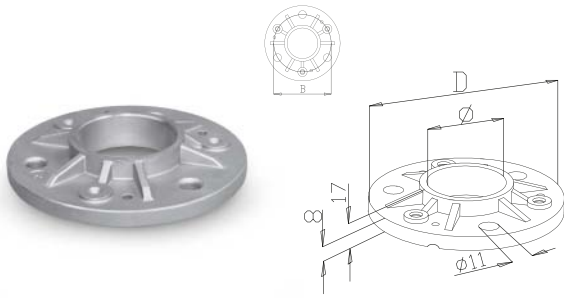

► 304 Model 1100

CODE	D	B	Ø
34.1100.420.R	105	80	42.4
34.1100.480.R	115	90	48.3

► 316's' Model 1100

CODE	D	B	Ø
36.1100.420.R	105	80	42.4
36.1100.480.R	115	90	48.3

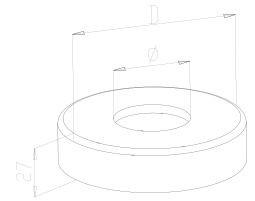

► 304 Model 1101

CODE	D	Ø
34.1101.420.S	110	42.4
34.1101.480.S	120	48.3

► 316's' Model 1101

CODE	D	Ø
36.1101.420.S	110	42.4
36.1101.480.S	120	48.3

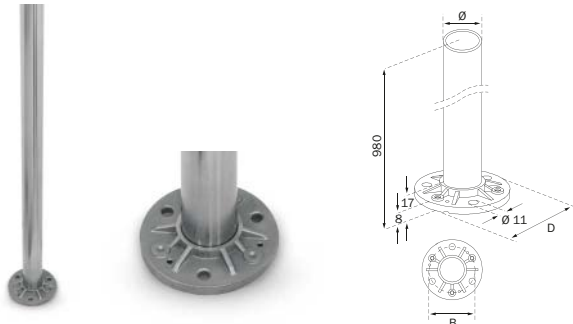

► 304 Model 1510

CODE	D	Ø	B
34.1510.426.S	105	42.4 x 2.6	80
34.1510.486.S	115	48.3 x 2.6	90

► 316 Model 1510

CODE	D	Ø	B
36.1510.426.S	105	42.4 x 2.6	80
36.1510.486.S	115	48.3 x 2.6	90

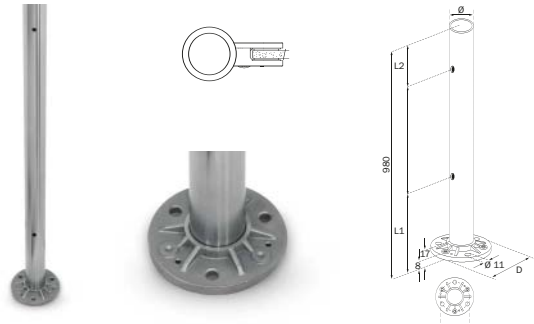

► 304 Model 1610

CODE	D	Ø	B	L1	L2
34.1610.426.S	105	42.4 x 2.6	80	195	120
34.1610.486.S	115	48.3 x 2.6	90	195	120

► 316 Model 1610

CODE	D	Ø	B	L1	L2
36.1610.426.S	105	42.4 x 2.6	80	195	120
36.1610.486.S	115	48.3 x 2.6	90	195	120

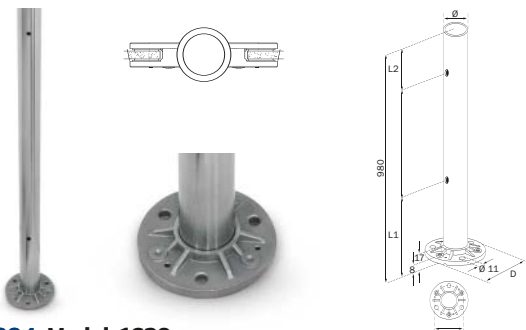

► 304 Model 1620

CODE	D	Ø	B	L1	L2
34.1620.426.S	105	42.4 x 2.6	80	195	120
34.1620.486.S	115	48.3 x 2.6	90	195	120

► 316 Model 1620

CODE	D	Ø	B	L1	L2
36.1620.426.S	105	42.4 x 2.6	80	195	120
36.1620.486.S	115	48.3 x 2.6	90	195	120

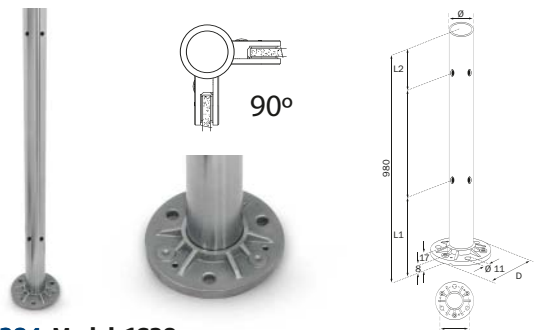

► 304 Model 1630

CODE	D	Ø	B	L1	L2
34.1630.426.S	105	42.4 x 2.6	80	195	120
34.1630.486.S	115	48.3 x 2.6	90	195	120

► 316 Model 1630

CODE	D	Ø	B	L1	L2
36.1630.426.S	105	42.4 x 2.6	80	195	120
36.1630.486.S	115	48.3 x 2.6	90	195	120

Welded Bases/Posts

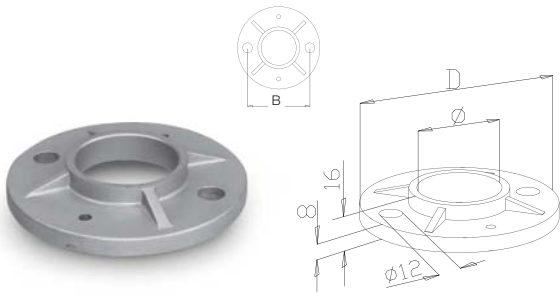

► 304 Model 1110

CODE	D	B	Ø
34.1110.420.R	100	75	42.4
34.1110.480.R	100	80	48.3

► 316's' Model 1110

CODE	D	B	Ø
36.1110.420.R	100	75	42.4
36.1110.480.R	100	80	48.3

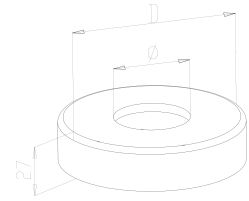

► 304 Model 1111

CODE	D	Ø
34.1111.420.S	105	42.4
34.1111.480.S	105	48.3

► 316's' Model 1111

CODE	H	Ø
36.1111.420.S	105	42.4
36.1111.480.S	105	48.3

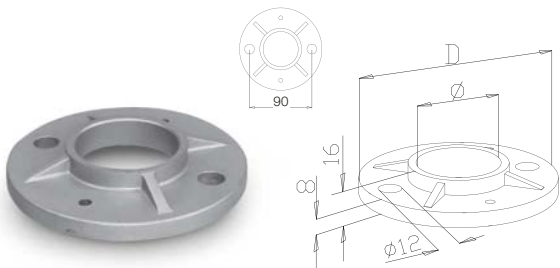

► 304 Model 1120

CODE	D	Ø
34.1120.420.R	120	42.4
34.1120.480.R	120	48.3

► 316's' Model 1120

CODE	D	Ø
36.1120.420.R	120	42.4
36.1120.480.R	120	48.3

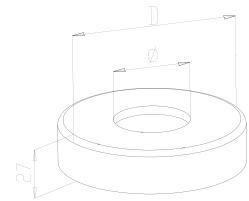

► 304 Model 1121

CODE	D	Ø
34.1121.420.S	125	42.4
34.1121.480.S	125	48.3

► 316's' Model 1121

CODE	H	Ø
36.1121.420.S	125	42.4
36.1121.480.S	125	48.3

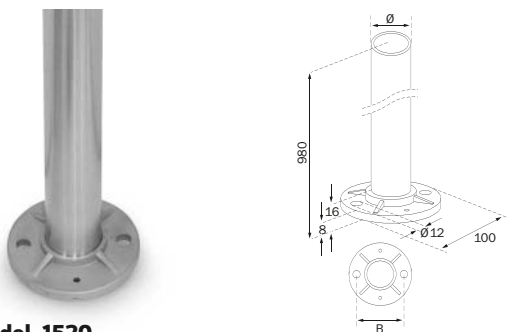

► 304 Model 1520

CODE	B	Ø
34.1520.426.S	75	42.4 x 2.6
34.1520.486.S	80	48.3 x 2.6

► 316 Model 1520

CODE	B	Ø
36.1520.426.S	75	42.4 x 2.6
36.1520.486.S	80	48.3 x 2.6

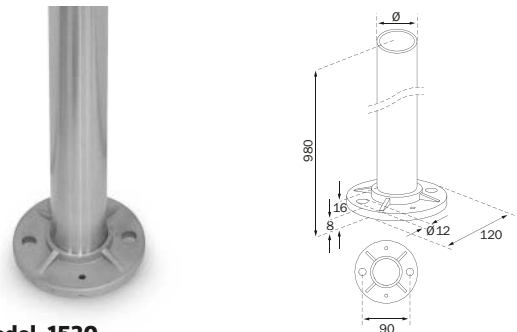

► 304 Model 1530

CODE	Ø
34.1530.426.S	42.4 x 2.6
34.1530.486.S	48.3 x 2.6

► 316 Model 1530

CODE	Ø
36.1530.426.S	42.4 x 2.6
36.1530.486.S	48.3 x 2.6

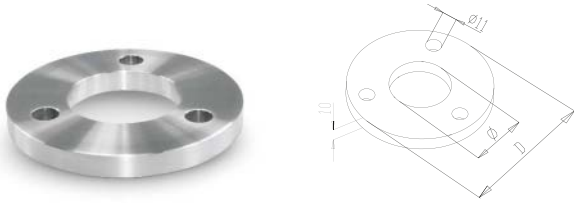

► **304 Model 1200**

CODE	D	Ø
34.1200.420.S	100	42.4
34.1200.480.S	100	48.3

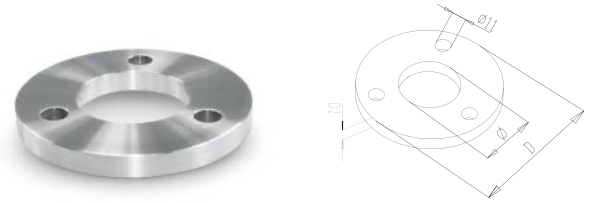

► **304 Model 1210**

CODE	D	Ø
34.1210.420.S	120	42.4
34.1210.480.S	120	48.3

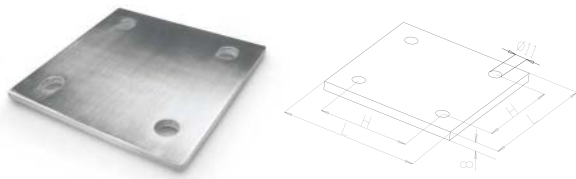

► **304 Model 1250**

CODE	L	H	Ø
34.1250.120.S	120	80	11

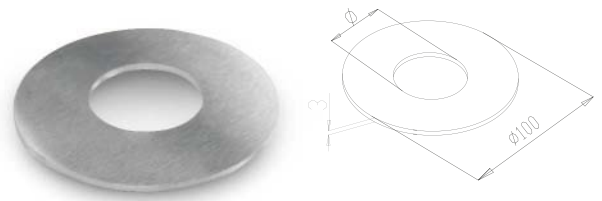

► **304 Model 1280**

CODE	Ø
34.1280.420.S	42.4
34.1280.480.S	48.3

► **316 Model 1280**

CODE	Ø
36.1280.420.S	42.4
36.1280.480.S	48.3

F ACCESSORIES



PAGE 69

Stainless Steel Cleaner
500 ml
10.9020.000.A

F ACCESSORIES



PAGE 69

Stain Remover
500 ml
10.9030.000.A

Welded Bases/Posts

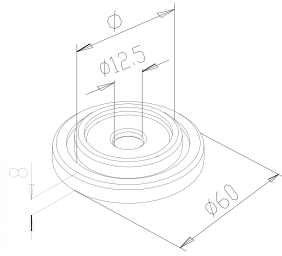

► 304 Model 1310

CODE	Ø
34.1310.420.S	42.4
34.1310.480.S	48.3

► 316's' Model 1310

CODE	Ø
36.1310.420.S	42.4
36.1310.480.S	48.3

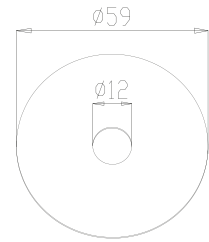

► Model 1321

CODE
10.1321.059.P

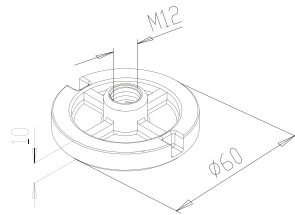

► 304 Model 1320

CODE
34.1320.060.S

► 316's' Model 1320

CODE
36.1320.060.S



► Model 1311

CODE
10.1311.059.P

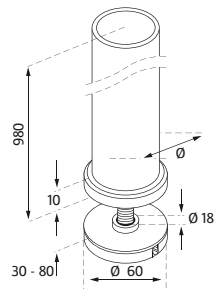

► 304 Model 1710

CODE	Ø
34.1710.426.S	42.4 x 2.6
34.1710.486.S	48.3 x 2.6

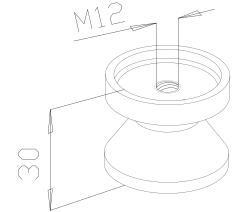

► 304 Model 1300

CODE	Ø
34.1300.426.R	42.4 x 2.6
34.1300.486.R	48.3 x 2.6

► 316's' Model 1300

CODE	Ø
36.1300.426.R	42.4 x 2.6
36.1300.486.R	48.3 x 2.6

E INFO



E ACCESSORIES



PAGE 69

Stainless Steel Cleaner
500 ml
10.9020.000.A

E ACCESSORIES



PAGE 69

Stain Remover
500 ml
10.9030.000.A

Crossbar Holders

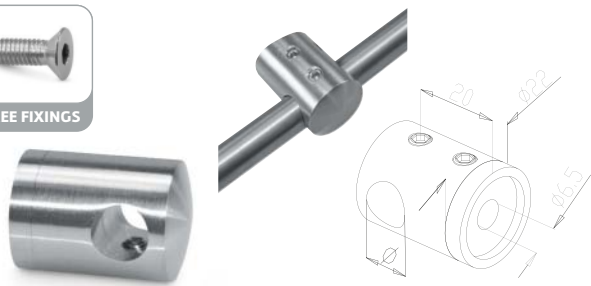
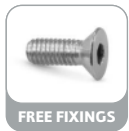

► 304 Model 2010/2012

CODE	Ø	BOLT
34.2010.000.S	10	FF-15
34.2012.000.S	12	FF-15

► 316's' Model 2012

CODE	Ø	BOLT
36.2012.000.S	12	FF-16

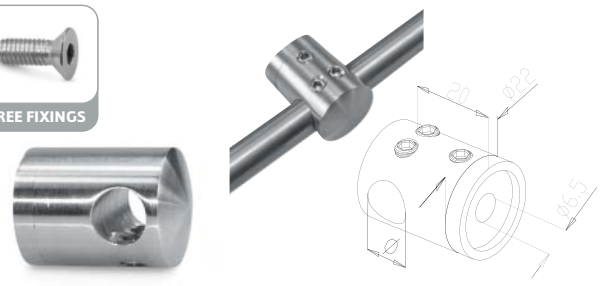
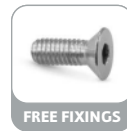

► 304 Model 2110/2112

CODE	Ø	BOLT
34.2110.000.S	10	FF-15
34.2112.000.S	12	FF-15

► 316's' Model 2012

CODE	Ø	BOLT
36.2112.000.S	12	FF-16

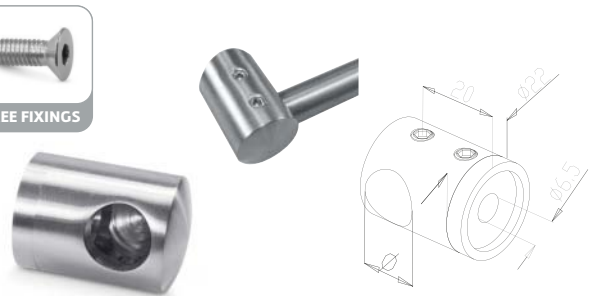
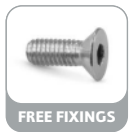

► 304 Model 2212

CODE	Ø	BOLT
34.2212.000.S	12	FF-15

► 316's' Model 2212

CODE	Ø	BOLT
36.2212.000.S	12	FF-16

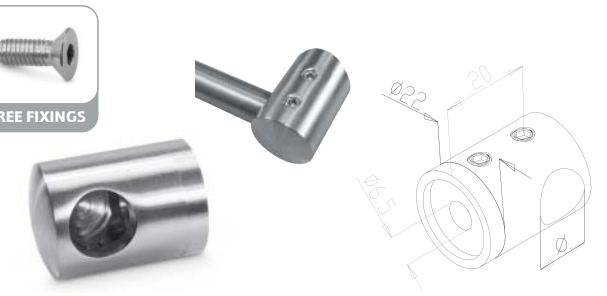
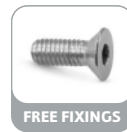

► 304 Model 2312

CODE	Ø	BOLT
34.2312.000.S	12	FF-15

► 316's' Model 2312

CODE	Ø	BOLT
36.2312.000.S	12	FF-16

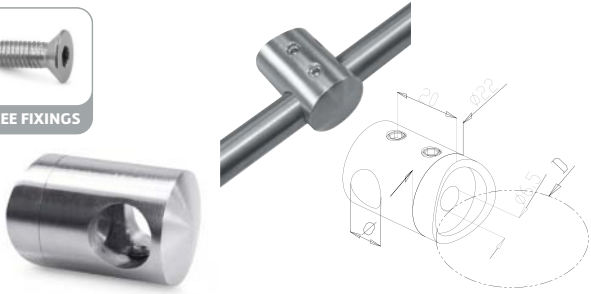

► 304 Model 2010/2012

CODE	D	Ø	BOLT
34.2010.420.S	42.4	10	FF-15
34.2012.420.S	42.4	12	FF-15
34.2012.480.S	48.3	12	FF-15

► 316's' Model 2012

CODE	D	Ø	BOLT
36.2012.420.S	42.4	12	FF-16
36.2012.480.S	48.3	12	FF-16

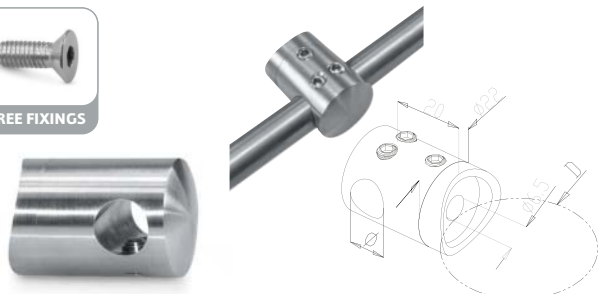
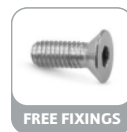

► 304 Model 2110/2112

CODE	D	Ø	BOLT
34.2110.420.S	42.4	10	FF-15
34.2112.420.S	42.4	12	FF-15
34.2112.480.S	48.3	12	FF-15

► 316's' Model 2112

CODE	D	Ø	BOLT
36.2112.420.S	42.4	12	FF-16
36.2112.480.S	48.3	12	FF-16

Crossbar Holders

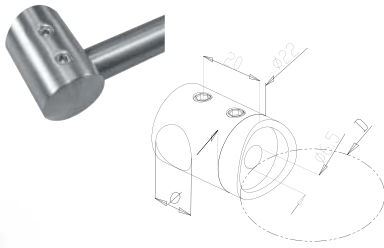
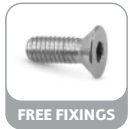

► 304 Model 2212

CODE	D	Ø	BOLT
34.2212.420.S	42.4	12	FF-15
34.2212.480.S	48.3	12	FF-15

► 316's' Model 2212

CODE	D	Ø	BOLT
36.2212.420.S	42.4	12	FF-16
36.2212.480.S	48.3	12	FF-16

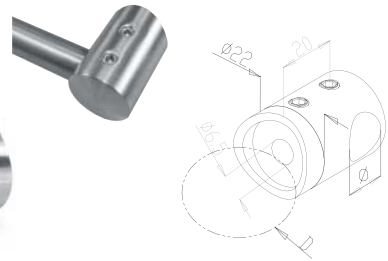
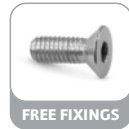

► 304 Model 2312

CODE	D	Ø	BOLT
34.2312.420.S	42.4	12	FF-15
34.2312.480.S	48.3	12	FF-15

► 316's' Model 2312

CODE	D	Ø	BOLT
36.2312.420.S	42.4	12	FF-16
36.2312.480.S	48.3	12	FF-16

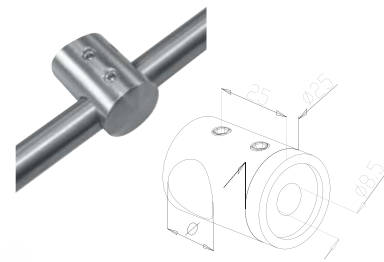
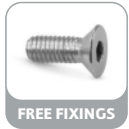

► 304 Model 2416

CODE	Ø	BOLT
34.2416.000.S	16	FF-19

► 316's' Model 2416

CODE	Ø	BOLT
36.2416.000.S	16	FF-20

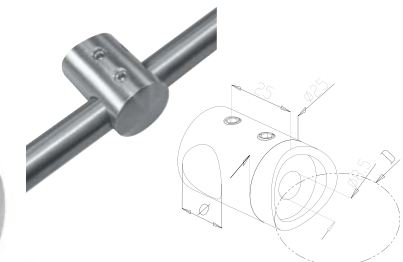
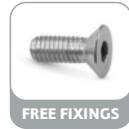

► 304 Model 2416

CODE	D	Ø	BOLT
34.2416.420.S	42.4	16	FF-19
34.2416.480.S	48.3	16	FF-19

► 316's' Model 2416

CODE	D	Ø	BOLT
36.2416.420.S	42.4	16	FF-20
36.2416.480.S	48.3	16	FF-20

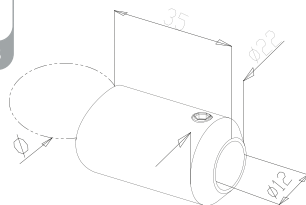

► 304 Model 2812

CODE	Ø	BOLT
34.2812.420.S	42.4	FF-15
34.2812.480.S	48.3	FF-15

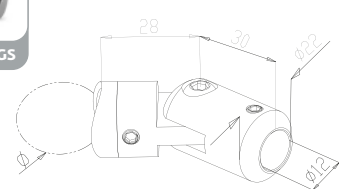
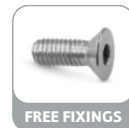

► 304 Model 2912

CODE	Ø	BOLT
34.2912.420.S	42.4	FF-15
34.2912.480.S	48.3	FF-15

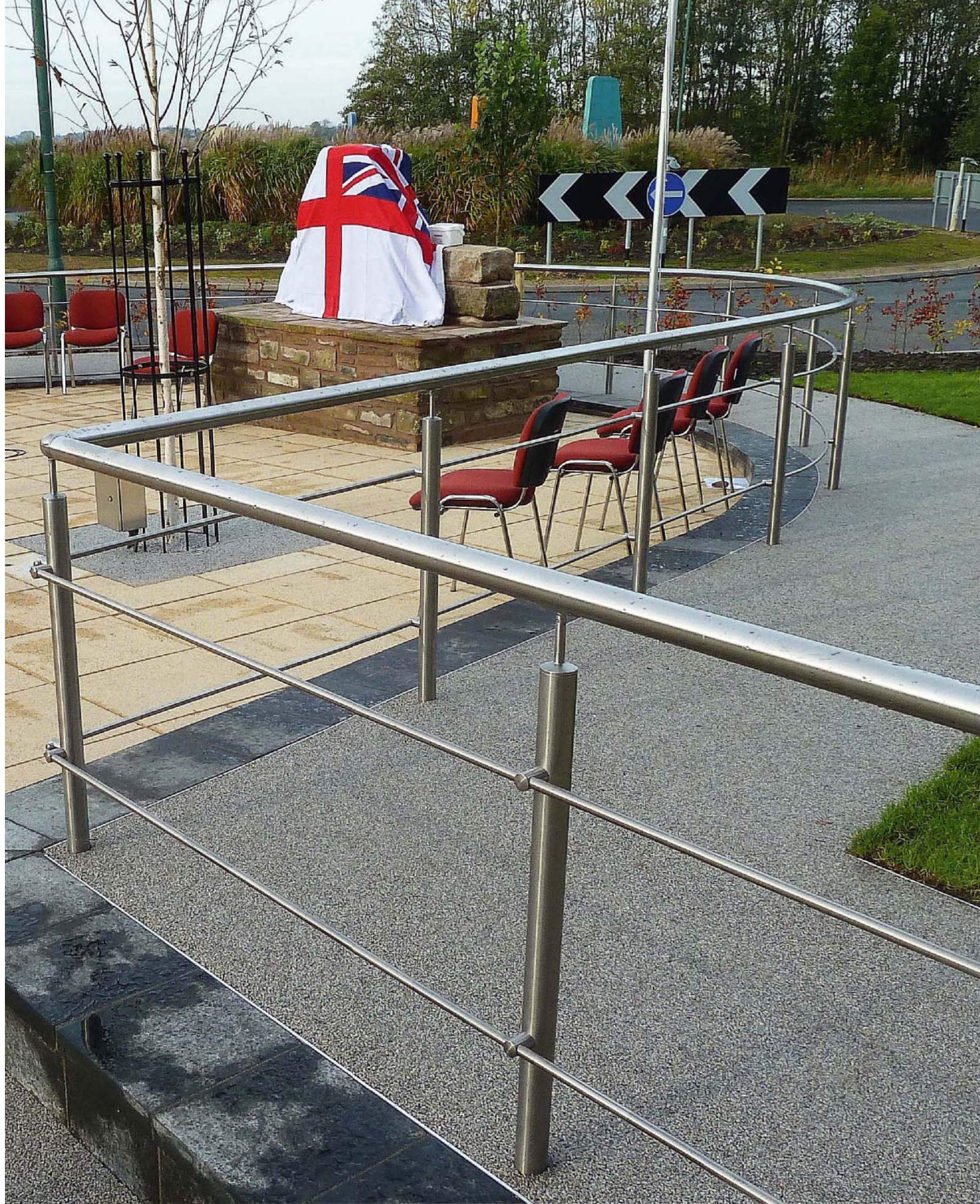

TUBES AND BARS

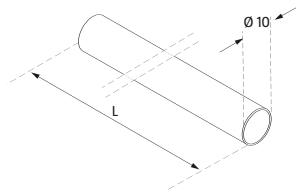

► 304 Ø 10mm Bar

CODE	L
34.1900.010.S	5000 mm
34.1910.010.S	2500 mm

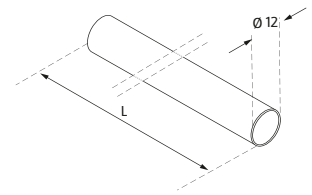

► 304 Ø 12mm Bar

CODE	L
34.1900.012.S	5000 mm
34.1910.012.S	2500 mm

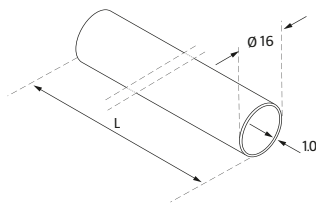

► 304 Ø 16mm Tube

CODE	L	T(mm)
34.1900.016.S	5000 mm	1.0
34.1910.016.S	2500 mm	1.0

► 316 Ø 16mm Tube

CODE	L	T(mm)
36.1900.016.S	5000 mm	1.0
36.1910.016.S	2500 mm	1.0

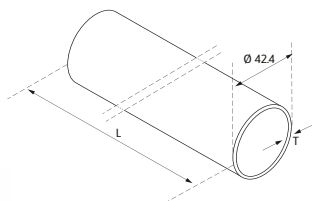

► 304 Ø 42.4mm Tube

CODE	L	T(mm)
34.1900.422.S	5000 mm	2.0
34.1900.426.S	5000 mm	2.6
34.1910.422.S	2500 mm	2.0
34.1910.426.S	2500 mm	2.6

► 316 Ø 42.4mm Tube

CODE	L	T(mm)
36.1900.422.S	5000 mm	2.0
36.1900.426.S	5000 mm	2.6
36.1910.422.S	2500 mm	2.0
36.1910.426.S	2500 mm	2.6

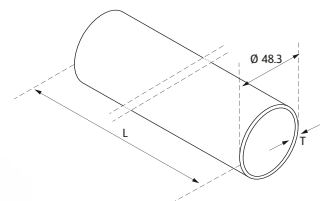

► 304 Ø 48.3mm Tube

CODE	L	T(mm)
34.1900.482.S	5000 mm	2.0
34.1900.486.S	5000 mm	2.6
34.1910.482.S	2500 mm	2.0
34.1910.486.S	2500 mm	2.6

► 316 Ø 48.3mm Tube

CODE	L	T(mm)
36.1900.482.S	5000 mm	2.0
36.1900.486.S	5000 mm	2.6
36.1910.482.S	2500 mm	2.0
36.1910.486.S	2500 mm	2.6



MIRROR POLISHED

Mirror Polished

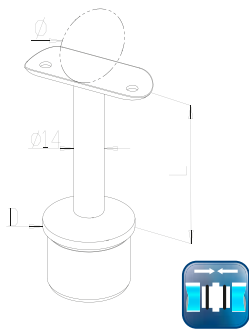
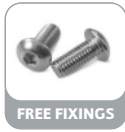

► 304 Model 0110 Stem Connector

CODE	D	L	Ø	BOLT
34.0110.426.M	42.4 x 2.6	80	42.4	FF-10
34.0110.486.M	48.3 x 2.6	80	48.3	FF-10

► 316's' Model 0110

CODE	D	L	Ø	BOLT
36.0110.426.M	42.4 x 2.6	80	42.4	FF-11
36.0110.486.M	48.3 x 2.6	80	48.3	FF-11

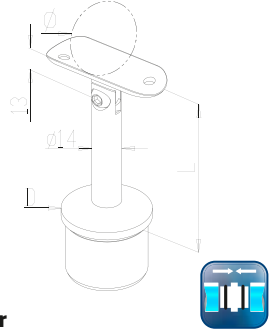
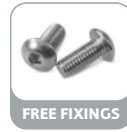

► 304 Model 0115 Stem Connector

CODE	D	L	Ø	BOLT
34.0115.426.M	42.4 x 2.6	80	42.4	FF-10
34.0115.486.M	48.3 x 2.6	80	48.3	FF-10

► 316's' Model 0115

CODE	D	L	Ø	BOLT
36.0115.426.M	42.4 x 2.6	80	42.4	FF-11
36.0115.486.M	48.3 x 2.6	80	48.3	FF-11

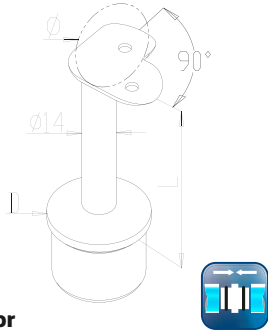

► 304 Model 0130 Stem Connector

CODE	D	L	Ø	BOLT
34.0130.426.M	42.4 x 2.6	80	42.4	FF-10
34.0130.486.M	48.3 x 2.6	80	48.3	FF-10

► 316's' Model 0130

CODE	D	L	Ø	BOLT
36.0130.426.M	42.4 x 2.6	80	42.4	FF-11
36.0130.486.M	48.3 x 2.6	80	48.3	FF-11

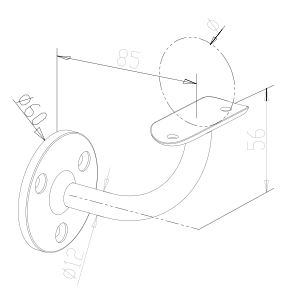
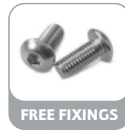

► 304 Model 0521 Handrail Bracket - Wall Fix

CODE	Ø	BOLT
34.0521.420.M	42.4	FF-10
34.0521.480.M	48.3	FF-10

► 316's' Model 0521

CODE	Ø	BOLT
36.0521.420.M	42.4	FF-11
36.0521.480.M	48.3	FF-11

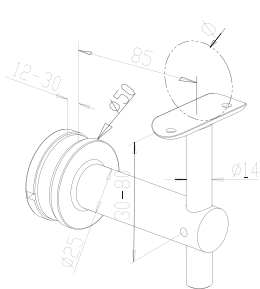
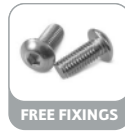

► 304 Model 0440 Handrail Bracket - Glass Fix

CODE	Ø	BOLT
34.0440.420.M	42.4	FF-10
34.0440.480.M	48.3	FF-10

► 316's' Model 0440

CODE	Ø	BOLT
36.0440.420.M	42.4	FF-11
36.0440.480.M	48.3	FF-11

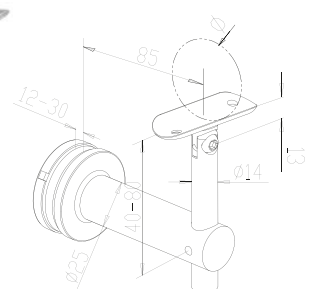
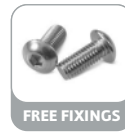

► 304 Model 0445 Handrail Bracket - Glass Fix

CODE	Ø	BOLT
34.0445.420.M	42.4	FF-10
34.0445.480.M	48.3	FF-10

► 316's' Model 0445

CODE	Ø	BOLT
36.0445.420.M	42.4	FF-11
36.0445.480.M	48.3	FF-11

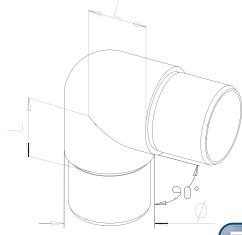

► **304 Model 0610 Elbow**

CODE	L	Ø
34.0610.426.M	30	42.4 x 2.6
34.0610.486.M	35	48.3 x 2.6

► **316's' Model 0610**

CODE	L	Ø
36.0610.426.M	30	42.4 x 2.6
36.0610.486.M	35	48.3 x 2.6

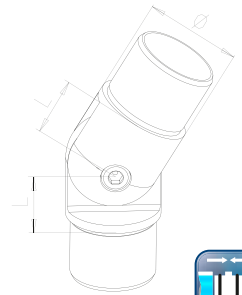

► **304 Model 0640 Elbow**

CODE	L	Ø
34.0640.426.M	27	42.4 x 2.6
34.0640.486.M	30	48.3 x 2.6

► **316's' Model 0640**

CODE	L	Ø
36.0640.426.M	27	42.4 x 2.6
36.0640.486.M	30	48.3 x 2.6

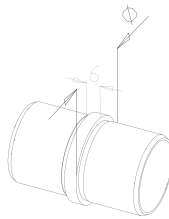

► **304 Model 0720 Connector**

CODE	Ø
34.0720.426.M	42.4 x 2.6
34.0720.486.M	48.3 x 2.6

► **316's' Model 0720**

CODE	Ø
36.0720.426.M	42.4 x 2.6
36.0720.486.M	48.3 x 2.6

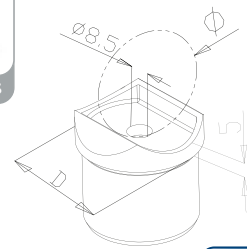
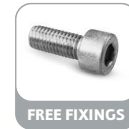

► **304 Model 0731 Connector**

CODE	D	Ø	BOLT
34.0731.426.M	42.4 x 2.6	42.4	FF-45
34.0731.486.M	48.3 x 2.6	48.3	FF-45

► **316's' Model 0731**

CODE	D	Ø	BOLT
36.0731.426.M	42.4 x 2.6	42.4	FF-46
36.0731.486.M	48.3 x 2.6	48.3	FF-46

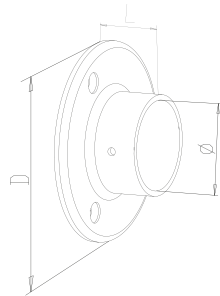

► **304 Model 0740 Wall Flange**

CODE	D	L	Ø
34.0740.420.M	95	30	42.4
34.0740.480.M	100	35	48.3

► **316's' Model 0740**

CODE	D	L	Ø
36.0740.420.M	95	30	42.4
36.0740.480.M	100	35	48.3

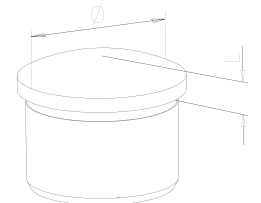

► **304 Model 0860 End Cap**

CODE	L	Ø
34.0860.426.M	9	42.4 x 2.6
34.0860.486.M	10	48.3 x 2.6

► **316's' Model 0860**

CODE	L	Ø
36.0860.426.M	9	42.4 x 2.6
36.0860.486.M	10	48.3 x 2.6

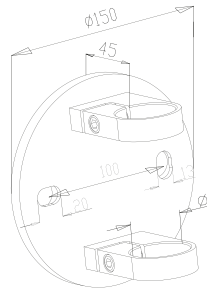

► **304 Model 1010 Side Fix Bracket**

CODE	Ø
34.1010.420.M	42.4
34.1010.480.M	48.3

► **316's' Model 1010**

CODE	Ø
36.1010.420.M	42.4
36.1010.480.M	48.3



► **304 Model 32 Glass Clamps**

CODE
SEE PAGE 49 FOR DETAILS

► **316's' Model 32**

CODE
SEE PAGE 49 FOR DETAILS

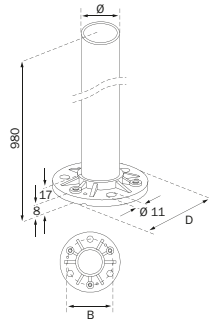

► **304 Model 1510 Baluster Post**

CODE	D	Ø	B
34.1510.426.M	105	42.4 x 2.6	80
34.1510.486.M	115	48.3 x 2.6	90

► **316 Model 1510**

CODE	D	Ø	B
36.1510.426.M	105	42.4 x 2.6	80
36.1510.486.M	115	48.3 x 2.6	90

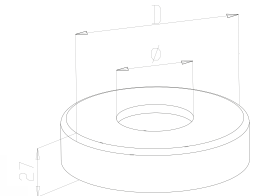

► **304 Model 1101 Base Cover**

CODE	D	Ø
34.1101.420.M	110	42.4
34.1101.480.M	120	48.3

► **316's' Model 1101**

CODE	D	Ø
36.1101.420.M	110	42.4
36.1101.480.M	120	48.3

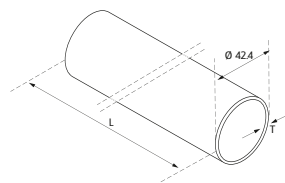

► **304 Ø 42.4 mm Tube**

CODE	L	T(mm)
34.1900.426.M	5000mm	2.6
34.1910.426.M	2500mm	2.6

► **316 Ø 42.4 mm Tube**

CODE	L	T(mm)
36.1900.426.M	5000mm	2.6
36.1910.426.M	2500mm	2.6

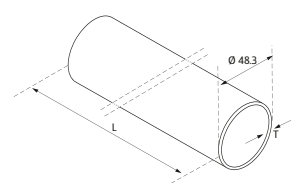

► **304 Ø 48.3 mm Tube**

CODE	L	T(mm)
34.1900.486.M	5000mm	2.6
34.1910.486.M	2500mm	2.6

► **316 Ø 48.3 mm Tube**

CODE	L	T(mm)
36.1900.486.M	5000mm	2.6
36.1910.486.M	2500mm	2.6



GLASS CLAMPS

Glass Clamps - Stainless/Zintec

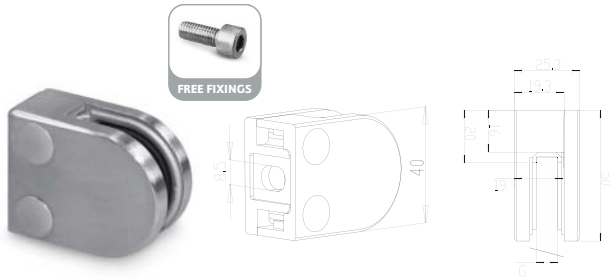

► 304 Model 30 Flat

CODE	G (mm)	BOLT
34.3006.000.S	6	FF-45
34.3008.000.S	8	FF-45

► 316's' Model 30 Flat

CODE	G (mm)	BOLT
36.3006.000.S	6	FF-46
36.3008.000.S	8	FF-46



► 304 Model 30 Rad

CODE	Ø	G (mm)	BOLT
34.3006.420.S	42.4	6	FF-45
34.3008.420.S	42.4	8	FF-45

► 316's' Model 30 Rad

CODE	Ø	G (mm)	BOLT
36.3006.420.S	42.4	6	FF-46
36.3008.420.S	42.4	8	FF-46

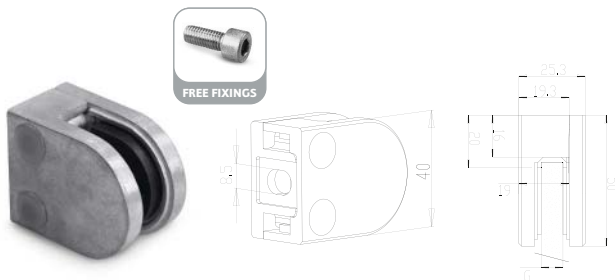

► ZINTEC Model 30 Flat

CODE	G (mm)	BOLT
20.3006.000.R	6	FF-47
20.3008.000.R	8	FF-47
20.3006.000.S	6	FF-47
20.3008.000.S	8	FF-47

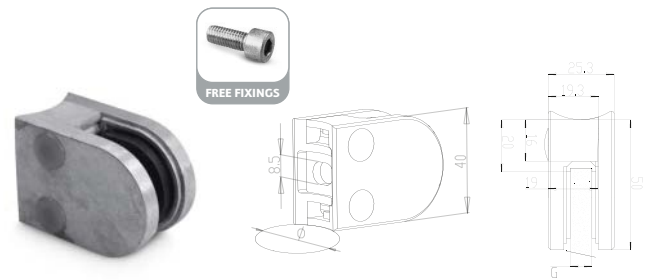

► ZINTEC Model 30 Rad

CODE	Ø	G (mm)	BOLT
20.3006.420.R	42.4	6	FF-47
20.3008.420.R	42.4	8	FF-47
20.3006.420.S	42.4	6	FF-47
20.3008.420.S	42.4	8	FF-47

F INFO

ZINTEC Finishes

R = Raw Finish

S = Satin Effect



F ACCESSORIES



PAGE 69

Glass Cleaner
500 ml
10.9025.000.A

Glass Clamps - Stainless/Zintec

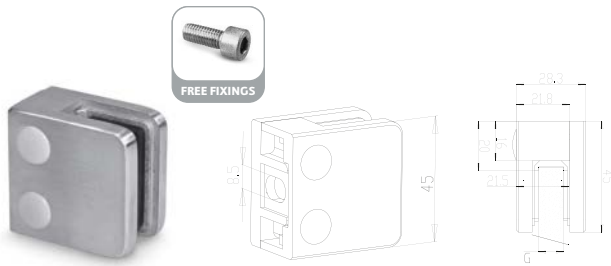

► 304 Model 31 Flat

CODE	G (mm)	BOLT
34.3106.000.S	6	FF-45
34.3108.000.S	8	FF-45
34.3110.000.S	10	FF-45
34.3109.000.S	8.76	FF-45
34.3144.000.S	9.52	FF-45

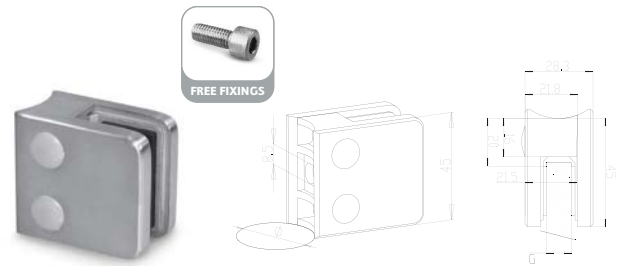

► 304 Model 31 Rad

CODE	Ø	G (mm)	BOLT
34.3106.420.S	42.4	6	FF-45
34.3108.420.S	42.4	8	FF-45
34.3110.420.S	42.4	10	FF-45
34.3109.420.S	42.4	8.76	FF-45
34.3144.420.S	42.4	9.52	FF-45

► 316's' Model 31 Flat

CODE	G (mm)	BOLT
36.3106.000.S	6	FF-46
36.3108.000.S	8	FF-46
36.3110.000.S	10	FF-46
36.3109.000.S	8.76	FF-46
36.3144.000.S	9.52	FF-46

► 316's' Model 31 Flat

CODE	Ø	G (mm)	BOLT
36.3106.420.S	42.4	6	FF-46
36.3108.420.S	42.4	8	FF-46
36.3110.420.S	42.4	10	FF-46
36.3109.420.S	42.4	8.76	FF-46
36.3144.420.S	42.4	9.52	FF-46

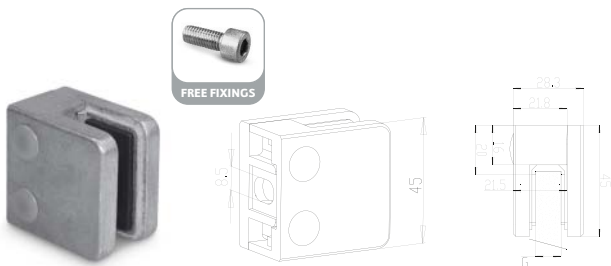

► ZINTEC Model 31 Flat

CODE	G (mm)	BOLT
20.3106.000.R	6	FF-47
20.3108.000.R	8	FF-47
20.3110.000.R	10	FF-47
20.3106.000.S	6	FF-47
20.3108.000.S	8	FF-47
20.3110.000.S	10	FF-47



► ZINTEC Model 31 Rad

CODE	Ø	G (mm)	BOLT
20.3106.420.R	42.4	6	FF-47
20.3108.420.R	42.4	8	FF-47
20.3110.420.R	42.4	10	FF-47
20.3106.420.S	42.4	6	FF-47
20.3108.420.S	42.4	8	FF-47
20.3110.420.S	42.4	10	FF-47

F INFO



Glass Clamps - Stainless/Zintec

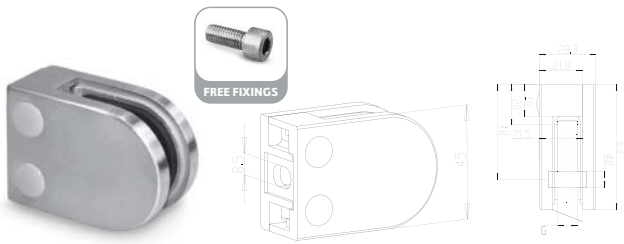

► 304 Model 32 Flat

CODE	G (mm)	BOLT
34.3206.000.S	6	FF-45
34.3208.000.S	8	FF-45
34.3210.000.S	10	FF-45
34.3209.000.S	8.76	FF-45
34.3244.000.S	9.52	FF-45

► 316's' Model 32 Flat

CODE	G (mm)	BOLT
36.3206.000.S	6	FF-46
36.3208.000.S	8	FF-46
36.3210.000.S	10	FF-46
36.3209.000.S	8.76	FF-46
36.3244.000.S	9.52	FF-46

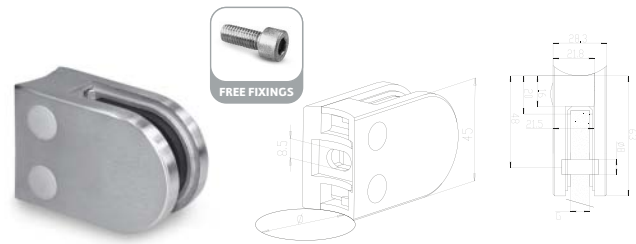

► 304 Model 32 Rad

CODE	Ø	G (mm)	BOLT
34.3206.420.S	42.4	6	FF-45
34.3208.420.S	42.4	8	FF-45
34.3210.420.S	42.4	10	FF-45
34.3209.420.S	42.4	8.76	FF-45
34.3244.420.S	42.4	9.52	FF-45
34.3206.480.S	48.3	6	FF-45
34.3208.480.S	48.3	8	FF-45
34.3210.480.S	48.3	10	FF-45
34.3209.480.S	48.3	8.76	FF-45
34.3244.480.S	48.3	9.52	FF-45

► 316's' Model 32 Rad

CODE	Ø	G (mm)	BOLT
36.3206.420.S	42.4	6	FF-46
36.3208.420.S	42.4	8	FF-46
36.3210.420.S	42.4	10	FF-46
36.3209.420.S	42.4	8.76	FF-46
36.3244.420.S	42.4	9.52	FF-46
36.3206.480.S	48.3	6	FF-46
36.3208.480.S	48.3	8	FF-46
36.3210.480.S	48.3	10	FF-46
36.3209.480.S	48.3	8.76	FF-46
36.3244.480.S	48.3	9.52	FF-46

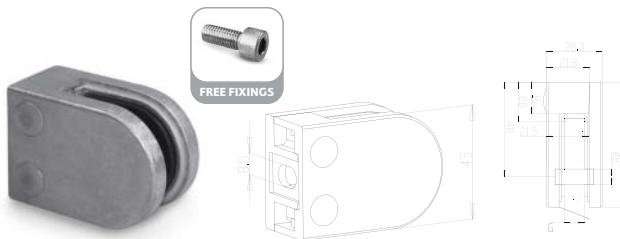

► ZINTEC Model 32 Flat

CODE	G (mm)	BOLT
20.3206.000.R	6	FF-47
20.3208.000.R	8	FF-47
20.3210.000.R	10	FF-47
20.3206.000.S	6	FF-47
20.3208.000.S	8	FF-47
20.3210.000.S	10	FF-47



► ZINTEC Model 32 Rad

CODE	Ø	G (mm)	BOLT
20.3206.420.R	42.4	6	FF-47
20.3208.420.R	42.4	8	FF-47
20.3210.420.R	42.4	10	FF-47
20.3206.480.R	48.3	6	FF-47
20.3208.480.R	48.3	8	FF-47
20.3210.480.R	48.3	10	FF-47
20.3206.420.S	42.4	6	FF-47
20.3208.420.S	42.4	8	FF-47
20.3210.420.S	42.4	10	FF-47
20.3206.480.S	48.3	6	FF-47
20.3208.480.S	48.3	8	FF-47
20.3210.480.S	48.3	10	FF-47

F INFO



Glass Clamps - Stainless/Mirror Polished

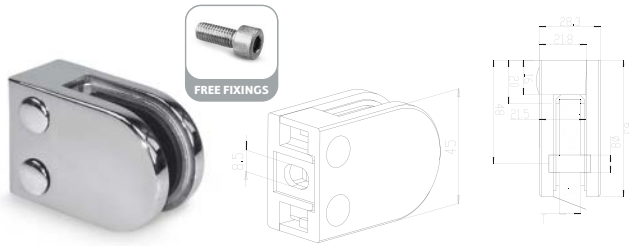

► 304 Model 32 Flat - Mirror Polished

CODE	G (mm)	BOLT
34.3206.000.M	6	FF-45
34.3208.000.M	8	FF-45
34.3210.000.M	10	FF-45
34.3209.000.M	8.76	FF-45
34.3244.000.M	9.52	FF-45

► 316's' Model 32 Flat - Mirror Polished

CODE	G (mm)	BOLT
36.3206.000.M	6	FF-46
36.3208.000.M	8	FF-46
36.3210.000.M	10	FF-46
36.3209.000.M	8.76	FF-46
36.3244.000.M	9.52	FF-46

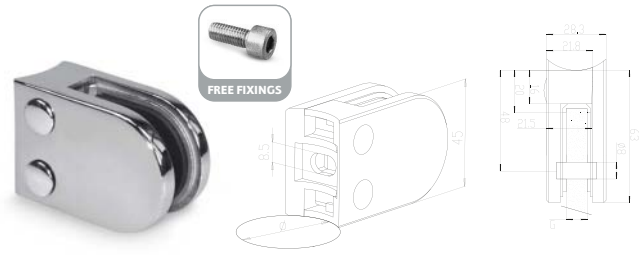

► 304 Model 32 Rad - Mirror Polished

CODE	Ø	G (mm)	BOLT
34.3206.420.M	42.4	6	FF-45
34.3208.420.M	42.4	8	FF-45
34.3210.420.M	42.4	10	FF-45
34.3209.420.M	42.4	8.76	FF-45
34.3244.420.M	42.4	9.52	FF-45
34.3206.480.M	48.3	6	FF-45
34.3208.480.M	48.3	8	FF-45
34.3210.480.M	48.3	10	FF-45
34.3209.480.M	48.3	8.76	FF-45
34.3244.480.M	48.3	9.52	FF-45

► 316's' Model 32 Rad - Mirror Polished

CODE	Ø	G (mm)	BOLT
36.3206.420.M	42.4	6	FF-46
36.3208.420.M	42.4	8	FF-46
36.3210.420.M	42.4	10	FF-46
36.3209.420.M	42.4	8.76	FF-46
36.3244.420.M	42.4	9.52	FF-46
36.3206.480.M	48.3	6	FF-46
36.3208.480.M	48.3	8	FF-46
36.3210.480.M	48.3	10	FF-46
36.3209.480.M	48.3	9.76	FF-46
36.3244.480.M	48.3	9.52	FF-46

F INFO

ZINTEC Finishes

R = Raw Finish



S = Satin Effect



F INFO



Glass Clamps - Stainless

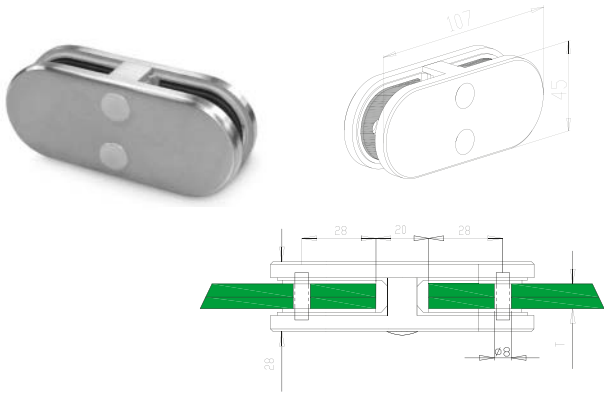

► 304 Model 32.100 Inline

CODE	G (mm)
34.3206.100.S	6
34.3208.100.S	8
34.3210.100.S	10
34.3209.100.S	8.76
34.3244.100.S	9.52

► 316's' Model 32.100 Inline

CODE	G (mm)
36.3206.100.S	6
36.3208.100.S	8
36.3210.100.S	10
36.3209.100.S	8.76
36.3244.100.S	9.52

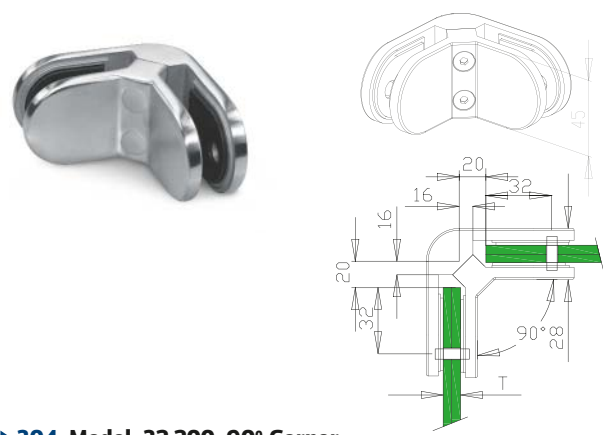

► 304 Model 32.200 90° Corner

CODE	G (mm)
34.3206.200.S	6
34.3208.200.S	8
34.3210.200.S	10
34.3209.200.S	8.76
34.3244.200.S	9.52

► 316's' Model 32.200 90° Corner

CODE	G (mm)
36.3206.200.S	6
36.3208.200.S	8
36.3210.200.S	10
36.3209.200.S	8.76
36.3244.200.S	9.52

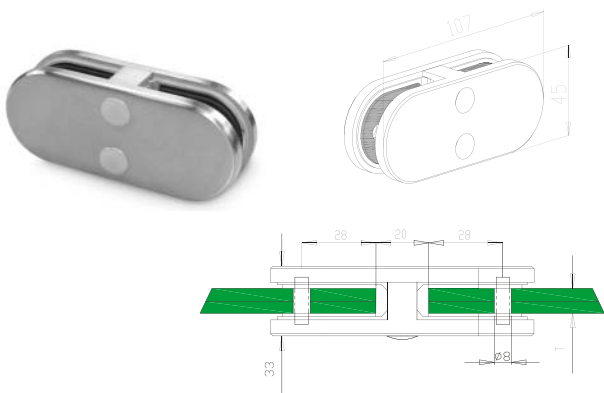

► 304 Model 33.100 Inline

CODE	G (mm)
34.3312.100.S	12
34.3315.100.S	15
34.3311.100.S	10.76
34.3313.100.S	12.76
34.3354.100.S	11.52
34.3364.100.S	13.52

► 316's' Model 33.100 Inline

CODE	G (mm)
36.3312.100.S	12
36.3315.100.S	15
36.3311.100.S	10.76
36.3313.100.S	12.76
36.3354.100.S	11.52
36.3364.100.S	13.52

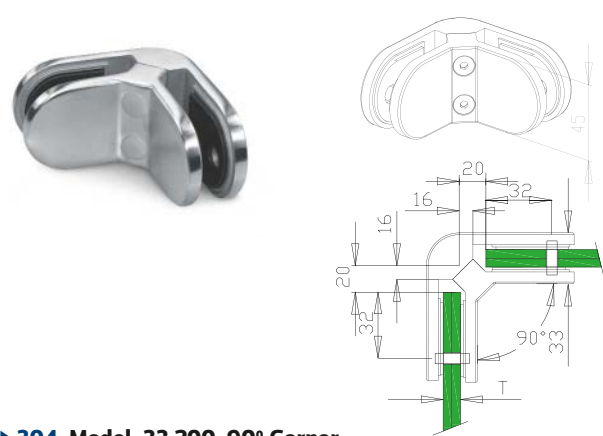

► 304 Model 33.200 90° Corner

CODE	G (mm)
34.3312.200.S	12
34.3315.200.S	15
34.3311.200.S	10.76
34.3313.200.S	12.76
34.3354.200.S	11.52
34.3364.200.S	13.52

► 316's' Model 33.200 90° Corner

CODE	G (mm)
36.3312.200.S	12
36.3315.200.S	15
36.3311.200.S	10.76
36.3313.200.S	12.76
36.3354.200.S	11.52
36.3364.200.S	13.52

Glass Clamps - Stainless/Zintec

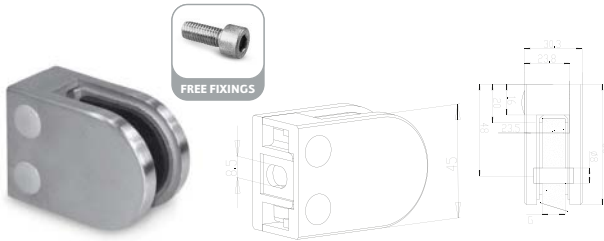

► 304 Model 33 Flat

CODE	G (mm)	BOLT
34.3312.000.S	12	FF-45
34.3311.000.S	10.76	FF-45
34.3313.000.S	12.76	FF-45
34.3354.000.S	11.52	FF-45

► 316's' Model 33 Flat

CODE	G (mm)	BOLT
36.3312.000.S	12	FF-46
36.3311.000.S	10.76	FF-46
36.3313.000.S	12.76	FF-46
36.3354.000.S	11.52	FF-46

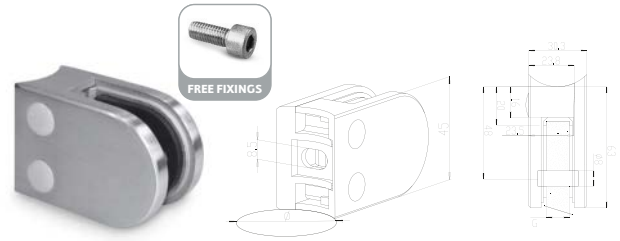

► 304 Model 33 Rad

CODE	Ø	G (mm)	BOLT
34.3312.420.S	42.4	12	FF-45
34.3311.420.S	42.4	10.76	FF-45
34.3313.420.S	42.4	12.76	FF-45
34.3354.420.S	42.4	11.52	FF-45
34.3312.480.S	48.3	12	FF-45
34.3311.480.S	48.3	10.76	FF-45
34.3313.480.S	48.3	12.76	FF-45
34.3354.480.S	48.3	11.52	FF-45

► 316's' Model 33 Rad

CODE	Ø	G (mm)	BOLT
36.3312.420.S	42.4	12	FF-46
36.3311.420.S	42.4	10.76	FF-46
36.3313.420.S	42.4	12.76	FF-46
36.3354.420.S	42.4	11.52	FF-46
36.3312.480.S	48.3	12	FF-46
36.3311.480.S	48.3	10.76	FF-46
36.3313.480.S	48.3	12.76	FF-46
36.3354.480.S	48.3	11.52	FF-46



► ZINTEC Model 33 Flat

CODE	G (mm)	BOLT
20.3312.000.R	12	FF-47
20.3312.000.S	12	FF-47

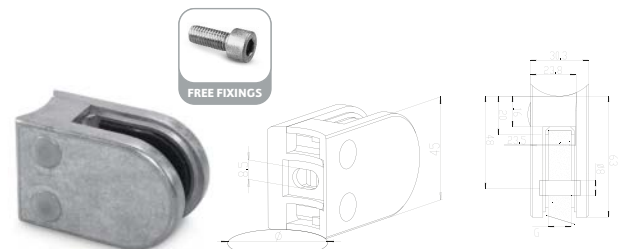

► ZINTEC Model 33 Rad

CODE	Ø	G (mm)	BOLT
20.3312.420.R	42.4	12	FF-47
20.3312.480.R	48.3	12	FF-47
20.3312.420.S	42.4	12	FF-47
20.3312.480.S	48.3	12	FF-47

F INFO

ZINTEC Finishes

R = Raw Finish

S = Satin Effect



F INFO



Glass Clamps - Stainless/Zintec

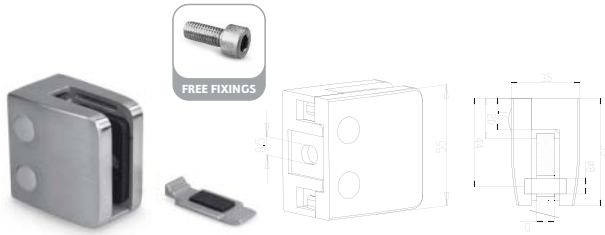

► 304 Model 34 Flat

CODE	G (mm)	BOLT
34.3408.000.S	8	FF-45
34.3410.000.S	10	FF-45
34.3412.000.S	12	FF-45
34.3411.000.S	10.76	FF-45
34.3454.000.S	11.52	FF-45
34.3413.000.S	12.76	FF-45

► 316's' Model 34 Flat

CODE	G (mm)	BOLT
36.3408.000.S	8	FF-46
36.3410.000.S	10	FF-46
36.3412.000.S	12	FF-46
36.3411.000.S	10.76	FF-46
36.3454.000.S	11.52	FF-46
36.3413.000.S	12.76	FF-45

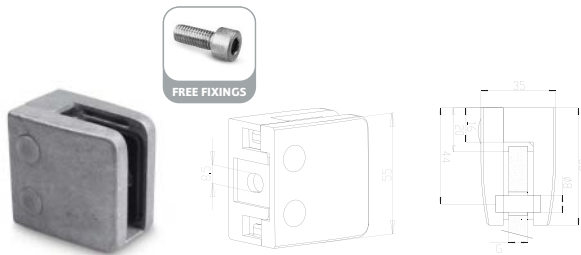

► ZINTEC Model 34 Flat

CODE	G (mm)	BOLT
20.3408.000.R	8	FF-47
20.3410.000.R	10	FF-47
20.3412.000.R	12	FF-47
20.3408.000.S	8	FF-47
20.3410.000.S	10	FF-47
20.3412.000.S	12	FF-47



► 304 Model 34 Rad

CODE	Ø	G (mm)	BOLT
34.3408.420.S	42.4	8	FF-45
34.3410.420.S	42.4	10	FF-45
34.3412.420.S	42.4	12	FF-45
34.3411.420.S	42.4	10.76	FF-45
34.3454.420.S	42.4	11.52	FF-45
34.3413.420.S	42.4	12.76	FF-45
34.3408.480.S	48.3	8	FF-45
34.3410.480.S	48.3	10	FF-45
34.3412.480.S	48.3	12	FF-45
34.3411.480.S	48.3	10.76	FF-45
34.3454.480.S	48.3	11.52	FF-45
34.3413.480.S	48.3	12.76	FF-45

► 316's' Model 34 Rad

CODE	Ø	G (mm)	BOLT
36.3408.420.S	42.4	8	FF-46
36.3410.420.S	42.4	10	FF-46
36.3412.420.S	42.4	12	FF-46
36.3411.420.S	42.4	10.76	FF-46
36.3454.420.S	42.4	11.52	FF-46
36.3413.420.S	42.4	12.76	FF-46
36.3408.480.S	48.3	8	FF-46
36.3410.480.S	48.3	10	FF-46
36.3412.480.S	48.3	12	FF-46
36.3411.480.S	48.3	10.76	FF-46
36.3454.480.S	48.3	11.52	FF-46
36.3413.480.S	48.3	12.76	FF-46

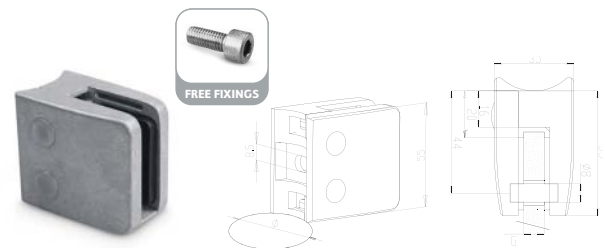

► ZINTEC Model 34 Rad

CODE	Ø	G (mm)	BOLT
20.3408.420.R	42.4	8	FF-47
20.3410.420.R	42.4	10	FF-47
20.3412.420.R	42.4	12	FF-47
20.3408.480.R	48.3	8	FF-47
20.3410.480.R	48.3	10	FF-47
20.3412.480.R	48.3	12	FF-47
20.3408.420.S	42.4	8	FF-47
20.3410.420.S	42.4	10	FF-47
20.3412.420.S	42.4	12	FF-47
20.3408.480.S	48.3	8	FF-47
20.3410.480.S	48.3	10	FF-47
20.3412.480.S	48.3	12	FF-47

F ACCESSORIES



PAGE 69

Glass Cleaner
500 ml
10.9025.000.A

Glass Clamps - Stainless/Zintec

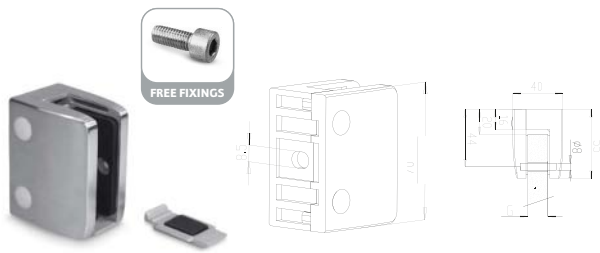

► 304 Model 35 Flat

CODE	G (mm)	BOLT
34.3510.000.S	10	FF-45
34.3512.000.S	12	FF-45
34.3513.000.S	13.52	FF-45
34.3515.000.S	15	FF-45
34.3517.000.S	17.52	FF-45

► 316's' Model 35 Flat

CODE	G (mm)	BOLT
36.3510.000.S	10	FF-46
36.3512.000.S	12	FF-46
36.3513.000.S	13.52	FF-46
36.3515.000.S	15	FF-46
36.3517.000.S	17.52	FF-46

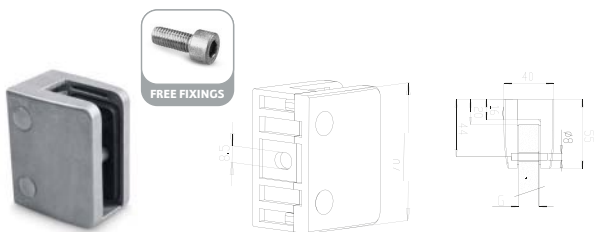

► ZINTEC Model 35 Flat

CODE	G (mm)	BOLT
20.3510.000.R	10	FF-47
20.3512.000.R	12	FF-47
20.3515.000.R	15	FF-47
20.3510.000.S	10	FF-47
20.3512.000.S	12	FF-47
20.3515.000.S	15	FF-47

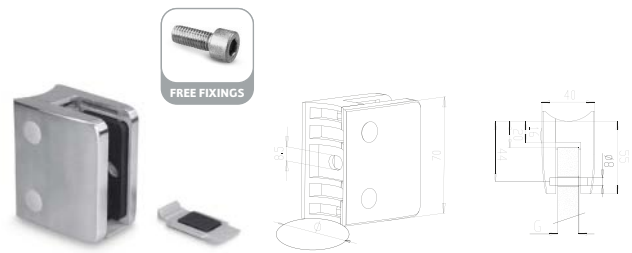

► 304 Model 35 Rad

CODE	Ø	G (mm)	BOLT
34.3510.480.S	48.3	10	FF-45
34.3512.480.S	48.3	12	FF-45
34.3513.480.S	48.3	13.52	FF-45
34.3515.480.S	48.3	15	FF-45
34.3517.480.S	48.3	17.52	FF-45

► 316's' Model 35 Rad

CODE	Ø	G (mm)	BOLT
36.3510.480.S	48.3	10	FF-46
36.3512.480.S	48.3	12	FF-46
36.3513.480.S	48.3	13.52	FF-46
36.3515.480.S	48.3	15	FF-46
36.3517.480.S	48.3	17.52	FF-46

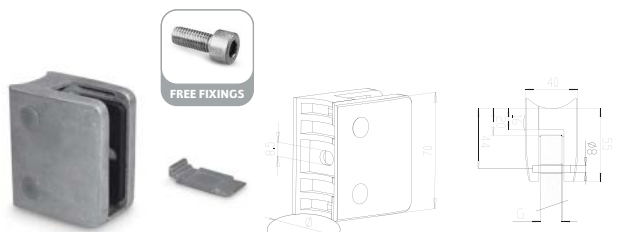

► ZINTEC Model 35 Rad

CODE	Ø	G (mm)	BOLT
20.3510.480.R	48.3	10	FF-47
20.3512.480.R	48.3	12	FF-47
20.3515.480.R	48.3	15	FF-47
20.3510.480.S	48.3	10	FF-47
20.3512.480.S	48.3	12	FF-47
20.3515.480.S	48.3	15	FF-47

F INFO

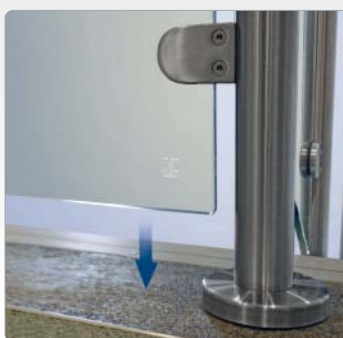

Glass Clamps - Stainless Steel

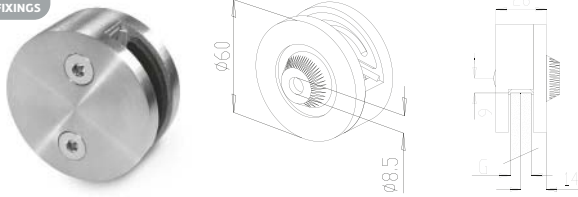

► 304 Model 38.100

CODE	G (mm)	BOLT
34.3808.100.S	8	FF-45
34.3810.100.S	10	FF-45
34.3812.100.S	12	FF-45

► 316's' Model 38.100

CODE	G (mm)	BOLT
36.3808.100.S	8	FF-46
36.3810.100.S	10	FF-46
36.3812.100.S	12	FF-46

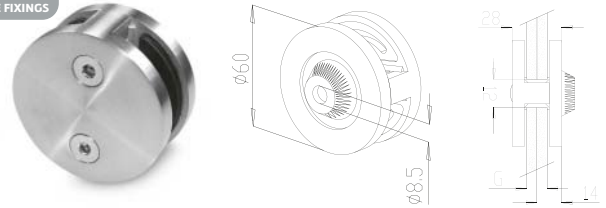

► 304 Model 38.200

CODE	G (mm)	BOLT
34.3808.200.S	8	FF-45
34.3810.200.S	10	FF-45
34.3812.200.S	12	FF-45

► 316's' Model 38.200

CODE	G (mm)	BOLT
36.3808.200.S	8	FF-46
36.3810.200.S	10	FF-46
36.3812.200.S	12	FF-46

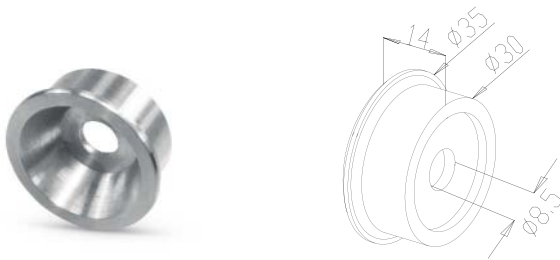

► 304 Model 38 Adaptor

CODE
34.3800.000.S

► 316's' Model 38 Adaptor

CODE
36.3800.000.S

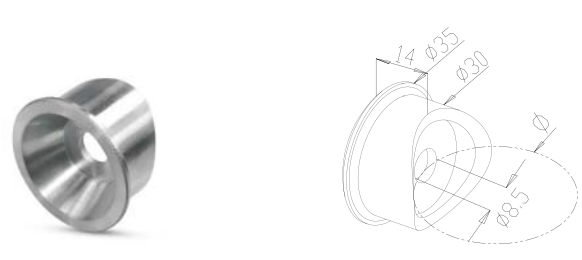

► 304 Model 38 Adaptor

CODE	Ø
34.3800.420.S	42.4
34.3800.480.S	48.3

► 316's' Model 38 Adaptor

CODE	Ø
36.3800.420.S	42.4
36.3800.480.S	48.3

F INFO

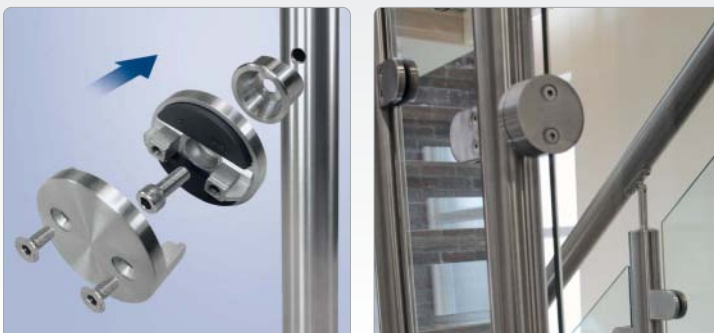

Glass Clamps - Rubbers



To Suit
Stainless Steel
Glass Clamps

Model 30 Rubbers (1 No. Pair)

CODE	CLAMP	G (mm)
40.3006.000.R	SS	6
40.3008.000.R	SS	8

Model 31 Rubbers (1 No. Pair)

CODE	CLAMP	G (mm)
40.3106.000.R	SS	6
40.3108.000.R	SS	8
40.3110.000.R	SS	10
40.3108.760.R	SS	8.76
40.3109.520.R	SS	9.52

Model 32 Rubbers (1 No. Pair)

CODE	CLAMP	G (mm)
40.3206.000.R	SS	6
40.3208.000.R	SS	8
40.3210.000.R	SS	10
40.3208.760.R	SS	8.76
40.3209.520.R	SS	9.52

Model 33 Rubbers (1 No. Pair)

CODE	CLAMP	G (mm)
40.3312.000.R	SS	12
40.3310.760.R	SS	10.76
40.3311.520.R	SS	11.52
40.3312.760.R	SS	12.76

Model 34 Rubbers (1 No. Pair)

CODE	CLAMP	G (mm)
40.3408.000.R	SS	8
40.3410.000.R	SS	10
40.3412.000.R	SS	12
40.3410.760.R	SS	10.76
40.3411.520.R	SS	11.52
40.3412.760.R	SS	12.76

Model 35 Rubbers (1 No. Pair)

CODE	CLAMP	G (mm)
40.3510.000.R	SS	10
40.3512.000.R	SS	12
40.3515.000.R	SS	15
40.3513.520.R	SS	13.52
40.3517.520.R	SS	17.52

Model 38.100 Rubbers (1 No. Pair)

CODE	CLAMP	G (mm)
40.3808.000.R	SS	8
40.3810.000.R	SS	10
40.3812.000.R	SS	12



To Suit
Double Headed
Glass Clamps

Model 32.100 & 32.200 Rubbers (1 No. Set of 4 Rubbers)

CODE	CLAMP	G (mm)
42.3206.000.R	SS	6
42.3208.000.R	SS	8
42.3210.000.R	SS	10
42.3208.760.R	SS	8.76
42.3209.520.R	SS	9.52

Model 33.100 & 33.200 Rubbers (1 No. Set of 4 Rubbers)

CODE	CLAMP	G (mm)
42.3310.760.R	SS	10.76
42.3311.520.R	SS	11.52
42.3312.000.R	SS	12
42.3312.760.R	SS	12.76
42.3313.520.R	SS	13.52
40.3315.000.R	SS	15

Model 38.200 Rubbers (1 No. Set of 4 Rubbers)

CODE	CLAMP	G (mm)
42.3808.000.R	SS	8
42.3810.000.R	SS	10
42.3812.000.R	SS	12



To Suit
Zintec
Glass Clamps

Model 30 Rubbers (1 No. Pair)

CODE	CLAMP	G (mm)
41.3006.000.R	Zintec	6
41.3008.000.R	Zintec	8

Model 31 Rubbers (1 No. Pair)

CODE	CLAMP	G (mm)
41.3106.000.R	Zintec	6
41.3108.000.R	Zintec	8
41.3110.000.R	Zintec	10

Model 32 Rubbers (1 No. Pair)

CODE	CLAMP	G (mm)
41.3206.000.R	Zintec	6
41.3208.000.R	Zintec	8
41.3210.000.R	Zintec	10

Model 33 Rubbers (1 No. Pair)

CODE	CLAMP	G (mm)
41.3312.000.R	Zintec	12

Model 34 Rubbers (1 No. Pair)

CODE	CLAMP	G (mm)
41.3408.000.R	Zintec	8
41.3410.000.R	Zintec	10
41.3412.000.R	Zintec	12

Model 35 Rubbers (1 No. Pair)

CODE	CLAMP	G (mm)
41.3510.000.R	Zintec	10
41.3512.000.R	Zintec	12
41.3515.000.R	Zintec	15

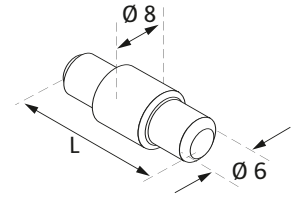

Model 30 Security Pins

CODE
40.4010.030.R

Model 32 Security Pins

CODE
40.4010.032.R

Model 33 Security Pins

CODE
40.4010.033.R

Model 34 Security Pins

CODE
40.4010.035.R



Cover Caps

CODE
40.4020.010.P



Cover Caps

CODE
40.4020.010.M



GLASS CONNECTORS & PANEL HOLDERS



► **304 Model 4010**

CODE
34.4010.000.S

► **316's' Model 4010**

CODE
36.4010.000.S

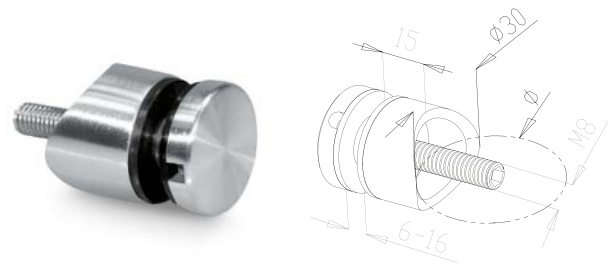

► **304 Model 4010**

CODE	Ø
34.4010.420.S	42.4
34.4010.480.S	48.3

► **316's' Model 4010**

CODE	Ø
36.4010.420.S	42.4
36.4010.480.S	48.3

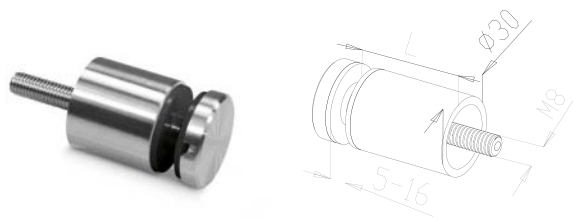

► **304 Model 4010**

CODE	L
34.4010.100.S	30

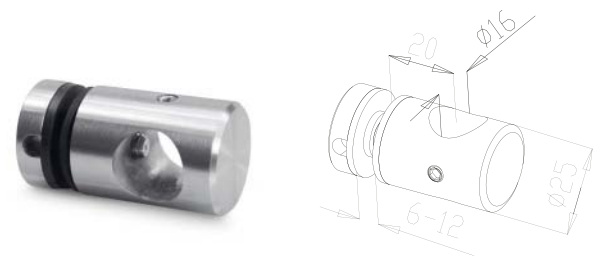

► **304 Model 4020**

CODE
34.4020.016.S

► **316's' Model 4020**

CODE
36.4020.016.S

E INFO

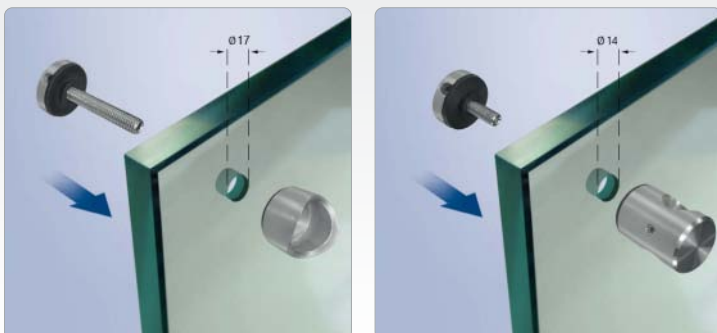

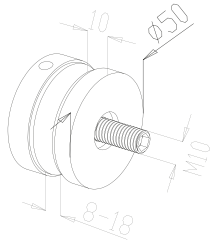

► **304 Model 4030**

CODE

34.4030.000.S

► **316's' Model 4030**

CODE

36.4030.000.S

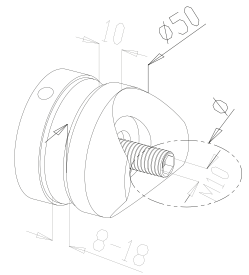

► **304 Model 4030**

CODE

34.4030.420.S

34.4030.480.S

Ø

42.4

48.3

► **316's' Model 4030**

CODE

36.4030.420.S

36.4030.480.S

Ø

42.4

48.3

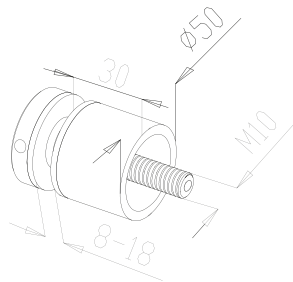

► **304 Model 4030**

CODE

34.4030.100.S

► **316's' Model 4030**

CODE

36.4030.100.S

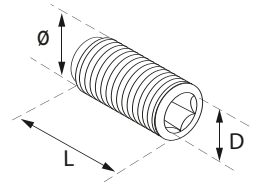

► **Model 9180 Threaded Insert (10 No.)**

CODE

20.9180.080.Z

20.9180.102.Z

20.9180.104.Z

D

M8

M10

M10

L

23

25

40

Ø

16

18.5

18.5

F ACCESSORIES



PAGE 69

Stain Remover
500 ml
10.9030.000.A

F INFO

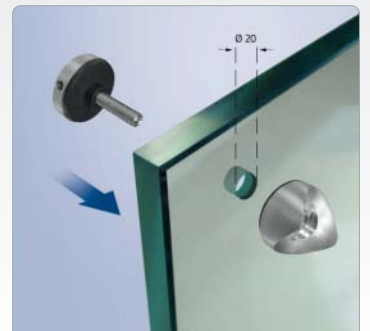

Panel Holders

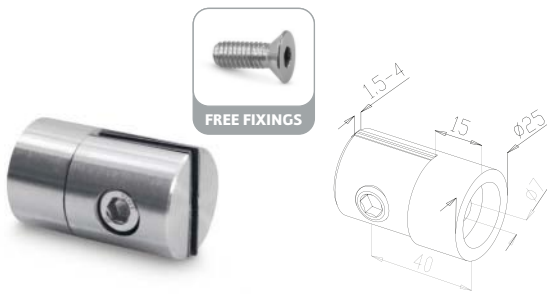

► 304 Model 4500

CODE	BOLT
34.4500.000.S	FF-15

► 316's' Model 4500

CODE	BOLT
36.4500.000.S	FF-16

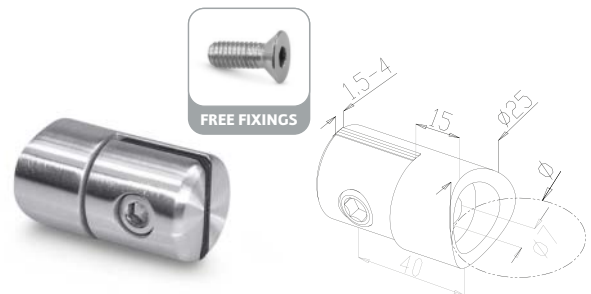

► 304 Model 4500

CODE	Ø	BOLT
34.4500.420.S	42.4	FF-15
34.4500.480.S	48.3	FF-15

► 316's' Model 4500

CODE	Ø	BOLT
36.4500.420.S	42.4	FF-16
36.4500.480.S	48.3	FF-16

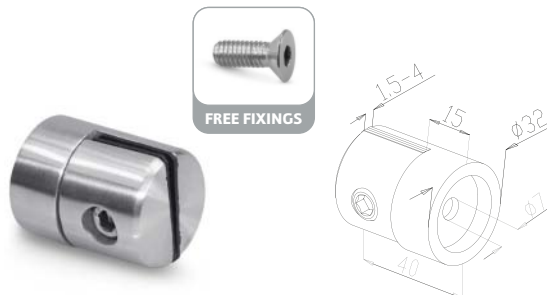

► 304 Model 4510

CODE	BOLT
34.4510.000.S	FF-15

► 316's' Model 4510

CODE	BOLT
36.4510.000.S	FF-16

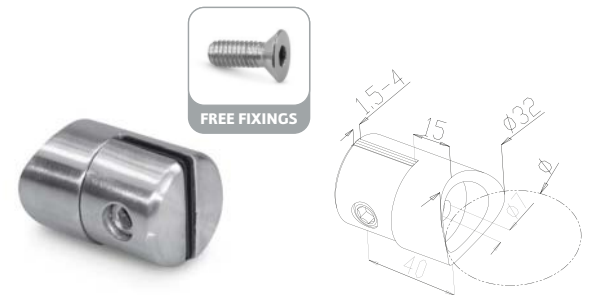

► 304 Model 4510

CODE	Ø	BOLT
34.4510.420.S	42.4	FF-15
34.4510.480.S	48.3	FF-15

► 316's' Model 4510

CODE	Ø	BOLT
36.4510.420.S	42.4	FF-16
36.4510.480.S	48.3	FF-16

F ACCESSORIES



PAGE 69

Stain Remover
500 ml
10.9030.000.A

F ACCESSORIES



PAGE 69

Internal Cleaner
500 ml
10.9025.000.A



WIRE-TEC

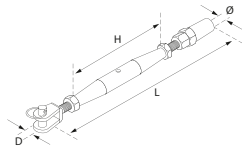

► **304 Model 6000 Tensioner With Jaw**

CODE	CABLE	Ø	D	H	L
34.6000.003.S	3.2mm	3.2	5	90	155 - 230
34.6000.006.S	6.0mm	6.0	7	125	200 - 290

► **316 Model 6000**

CODE	CABLE	Ø	D	H	L
36.6000.003.S	3.2mm	3.2	5	90	155 - 230
36.6000.006.S	6.0mm	6.0	7	125	200 - 290

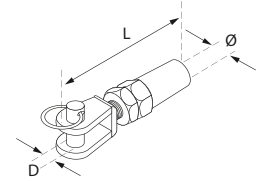

► **304 Model 6010 Terminal With Jaw**

CODE	CABLE	Ø	D	L
34.6010.003.S	3.2mm	3.2	5	50
34.6010.006.S	6.0mm	6.0	7	70

► **316 Model 6010**

CODE	CABLE	Ø	D	L
36.6010.003.S	3.2mm	3.2	5	50
36.6010.006.S	6.0mm	6.0	7	70

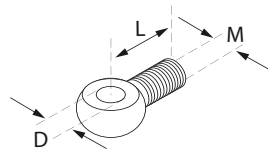

► **304 Model 6020 Eye Bolt**

CODE	M	D	L
34.6020.003.S	M6	6.0	19
34.6020.006.S	M10	8.0	30

► **316 Model 6020**

CODE	M	D	L
36.6020.003.S	M6	6.0	19
36.6020.006.S	M10	8.0	30

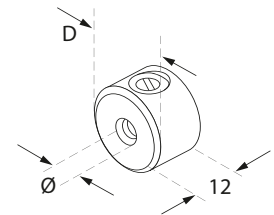

► **304 Model 6030 Cable Stopper**

CODE	CABLE	Ø	D
34.6030.003.S	3.2mm	3.5	18
34.6030.006.S	6.0mm	6.5	20

► **316 Model 6030**

CODE	CABLE	Ø	D
36.6030.003.S	3.2mm	3.5	18
36.6030.006.S	6.0mm	6.5	20

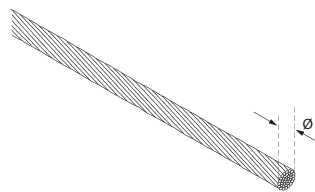

► **304 Model 6203/6206 Cable (1 x 19)**

CODE	Ø	L
34.6203.010.S	3.2	10M
34.6203.050.S	3.2	50M
34.6203.100.S	3.2	100M
34.6206.010.S	6.0	10M
34.6206.050.S	6.0	50M
34.6206.100.S	6.0	100M

► **316 Model 6203/6206**

CODE	Ø	L
36.6203.010.S	3.2	10M
36.6203.050.S	3.2	50M
36.6203.100.S	3.2	100M
36.6206.010.S	6.0	10M
36.6206.050.S	6.0	50M
36.6206.100.S	6.0	100M



► **Model 6350 Cable Cutters**

CODE	Ø
10.6350.000.T	3.2



INFO

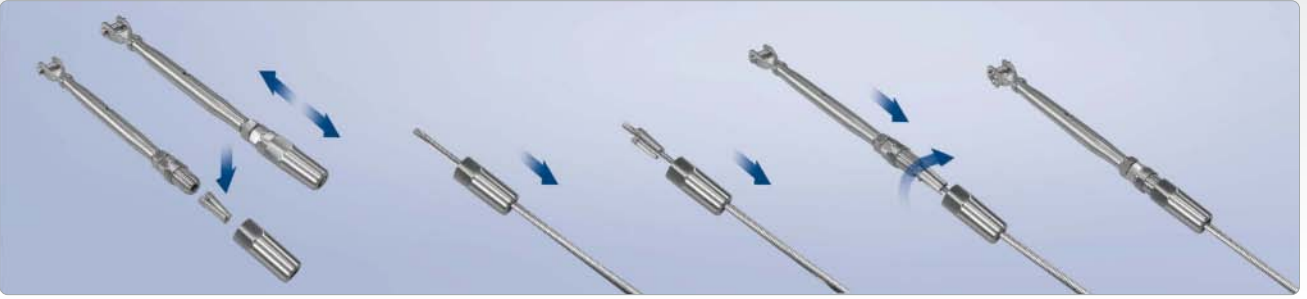

INFO

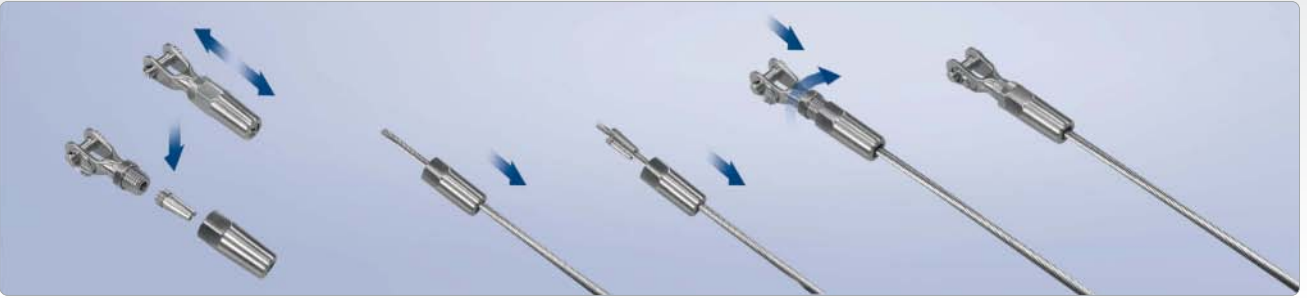

INFO



INFO



INFO





► **304 Model 6100 Tensioner With Thread**

CODE	CABLE
34.6100.003.S	3.2mm

► **316 Model 6100**

CODE	CABLE
36.6100.003.S	3.2mm

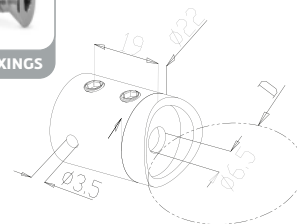
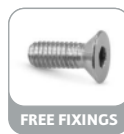

► **304 Model 6130 Crossbar Holder For Cable**

CODE	CABLE	D	BOLT
34.6130.420.S	3.2mm	42.4	FF-15
34.6130.480.S	3.2mm	48.3	FF-15

► **316 Model 6130**

CODE	CABLE	D	BOLT
36.6130.420.S	3.2mm	42.4	FF-16
36.6130.480.S	3.2mm	48.3	FF-16

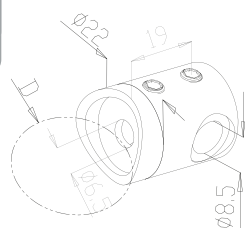
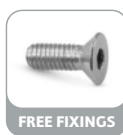

► **304 Model 6110 Crossbar Holder For Tensioner - Left**

CODE	D	BOLT
34.6110.420.S	42.4	FF-15
34.6110.480.S	48.3	FF-15

► **316 Model 6110**

CODE	D	BOLT
36.6110.420.S	42.4	FF-16
36.6110.480.S	48.3	FF-16

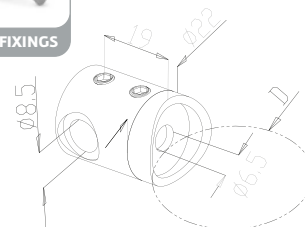
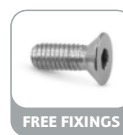

► **304 Model 6120 Crossbar Holder For Tensioner - Right**

CODE	D	BOLT
34.6120.420.S	42.4	FF-15
34.6120.480.S	48.3	FF-15

► **316 Model 6120**

CODE	D	BOLT
36.6120.420.S	42.4	FF-16
36.6120.480.S	48.3	FF-16



► **304 Model 6203 Cable 3.2mm (1 x 19)**

CODE	Ø	L
34.6203.010.S	3.2	10M
34.6203.050.S	3.2	50M
34.6203.100.S	3.2	100M

► **316 Model 6203**

CODE	Ø	L
36.6203.010.S	3.2	10M
36.6203.050.S	3.2	50M
36.6203.100.S	3.2	100M



TIMBER-TEC

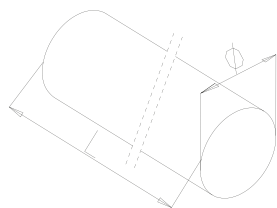

► **Model 8000 Beech Handrail**

CODE	Ø	L
22.8000.420.B	42	2400
22.8000.480.B	48	2400

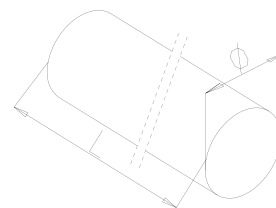

► **Model 8000 Oak Handrail**

CODE	Ø	L
22.8000.420.O	42	2400
22.8000.480.O	48	2400



► **304 Model 8010 Elbow**

CODE	Ø	L	BOLT
34.8010.420.S	42	60	FF-6
34.8010.480.S	48	65	FF-6



► **304 Model 8020 Elbow**

CODE	Ø	L	BOLT
34.8020.420.S	42	50	FF-6
34.8020.480.S	48	55	FF-6

E INFO



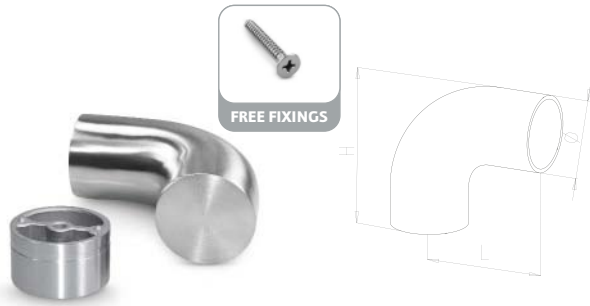

► **304 Model 8030 Return End**

CODE	Ø	L	H	BOLT
34.8030.420.S	42	70	91	FF-6
34.8030.480.S	48	75	89	FF-6



► **304 Model 8040 End Cap**

CODE	Ø	L	BOLT
34.8040.420.S	42	30	FF-6
34.8040.480.S	48	35	FF-6



► **304 Model 8050 Connector**

CODE	Ø	L	BOLT
34.8050.420.S	42	60	FF-6
34.8050.480.S	48	65	FF-6



► **304 Model 8060 Spigot**

CODE	Ø	L	BOLT
34.8060.420.S	42	21	FF-6
34.8060.480.S	48	23	FF-6



► **Model 6400 Aligning Tool**

CODE	Ø
10.6400.420.T	42
10.6400.480.T	48



ACCESSORIES

Accessories



► **Model 9010 Glue**

CODE

10.9010.000.A

50 ml



► **Model 9030 Stain Remover**

CODE

10.9030.000.A

500 ml



► **Model 9020 Stainless Steel Cleaner**

CODE

10.9020.000.A

500 ml



► **Model 9025 Glass Cleaner**

CODE

10.9025.000.A

500 ml



► **Model 9027 Stainless Steel & Glass Cleaner Kit**

CODE

10.9027.000.A

500 ml



► **Model 9200 'C' Spanner**

CODE

10.9200.025.T

Ø

25-28

10.9200.030.T

30-32

10.9200.045.T

45-50

10.9200.058.T

58-62



► **Model 9300 Allen Key Set**

CODE

10.9300.000.T

Ø

1.5, 2.0, 2.5, 3.0, 4.0, 5.0, 6.0, 8.0

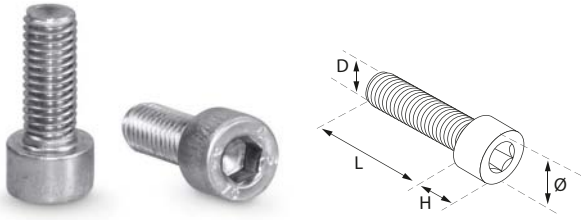

► **304 Model 9100 Socket Headed Cap Screw (20 No.)**

CODE	Ø	D	H	L	BOLT
34.9100.820.R	13	M8	8	20	FF-45
34.9100.835.R	13	M8	8	35	FF-29

► **316 Model 9100**

CODE	Ø	D	H	L	BOLT
36.9100.820.R	13	M8	8	20	FF-46
36.9100.835.R	13	M8	8	35	FF-30

► **ZINC PLATED Model 9100**

CODE	Ø	D	H	L	BOLT
20.9100.820.Z	13	M8	8	20	FF-47

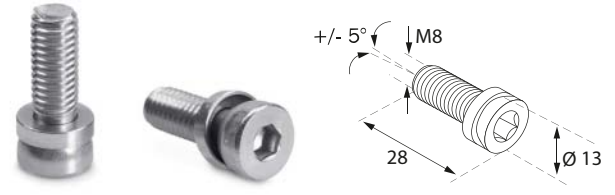

► **304 Model 9101 Adjustable Socket Headed Cap Screw (20 No.)**

CODE	Ø	D	H	L
34.9101.820.R	13	M8	8	20

► **316 Model 9101**

CODE	Ø	D	H	L
36.9101.820.R	13	M8	8	20

► **ZINC PLATED Model 9101**

CODE	Ø	D	H	L
20.9101.820.Z	13	M8	8	20

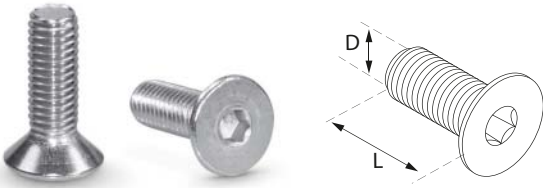

► **304 Model 9110 Counter Sunk Screw (20 No.)**

CODE	D	L	BOLT
34.9110.516.R	M5	16	FF-12
34.9110.612.R	M6	12	FF-50
34.9110.616.R	M6	16	FF-48
34.9110.620.R	M6	20	FF-15
34.9110.825.R	M8	25	FF-19
34.9110.840.R	M8	40	FF-21

► **316 Model 9110**

CODE	D	L	BOLT
36.9110.516.R	M5	16	FF-13
36.9110.612.R	M6	12	FF-51
36.9110.616.R	M6	16	FF-49
36.9110.620.R	M6	20	FF-16
36.9110.825.R	M8	25	FF-20
36.9110.840.R	M8	40	FF-22

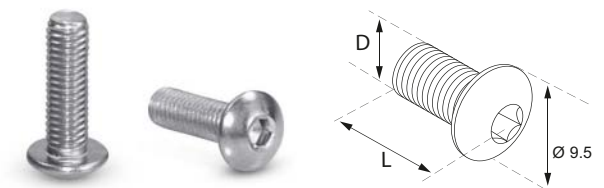

► **304 Model 9120 Button Head Screw (20 No.)**

CODE	D	L	BOLT
34.9120.512.R	M5	12	FF-10

► **316 Model 9120**

CODE	D	L	BOLT
36.9120.512.R	M5	12	FF-11

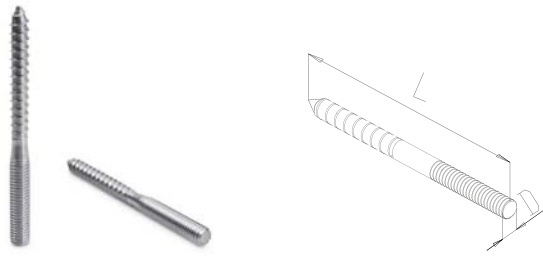

► **304 Model 9160 Dual Thread Screw (20 No.)**

CODE	D	L
34.9160.850.R	M8	50

► **316 Model 9160**

CODE	D	L
36.9160.850.R	M8	50

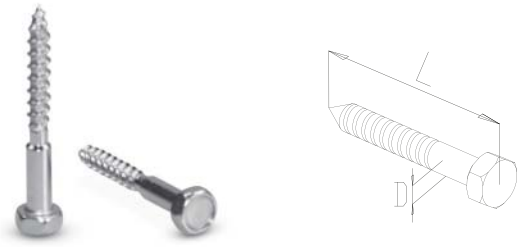

► **304 Model 9165 Coach Screw (20 No.)**

CODE	D	L
34.9165.855.R	M8	55

► **316 Model 9165**

CODE	D	L
36.9165.855.R	M8	55

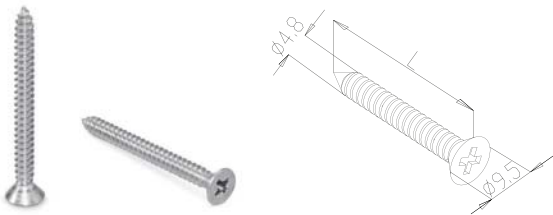

► **304 Model 9170 Screw (20 No.)**

CODE	L	BOLT
34.9170.840.R	40	FF-6

► **316 Model 9170**

CODE	L	BOLT
36.9170.840.R	40	

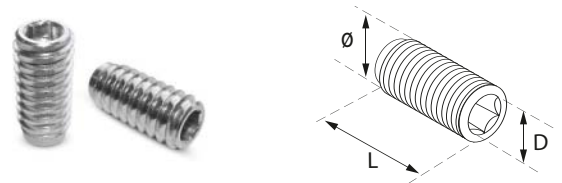

► **Model 9180 Threaded Insert (10 No.)**

CODE	D	L	Ø
20.9180.080.Z	M8	23	16
20.9180.102.Z	M10	25	18.5
20.9180.104.Z	M10	40	18.5



The complete solution
FREE FIXINGS

We listened to your needs and have responded by providing all the fixings you need to assemble your Fastec Handrail System.

All the bolts and screws for each fitting will be supplied with your order to allow you to concentrate on assembling and building your system together saving you both time and money.

Please refer to the individual fittings for information and details on the bolts and screws supplied.

Whilst we supply the bolts and screws for fastening the system together we do not supply the fasteners to secure the fittings to floors and walls, if you are unsure which fittings are supplied please refer to the information stated on each fitting.

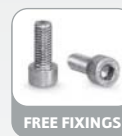

Look out for the **FREE FIXINGS** offer. Please call for further details.



Enquiry Sheets

Posts Made To Your Requirements

Base

 MOD: 1100

 MOD: 1110

 MOD: 1120
Specials form

 Ø 42,4 x 2,0 mm

 Ø 42,4 x 2,6 mm

 Ø 48,3 x 2,0 mm

 Ø 48,3 x 2,6 mm
Grade

 304

 316

See page 29 & 30

Type				Quantity	
	Glass clamps L=980 mm <input type="checkbox"/> L=1060 mm <input type="checkbox"/> or L: _____ mm L1: _____ mm L2: _____ mm	Glass clamp MOD: 30 <input type="checkbox"/> MOD: 31 <input type="checkbox"/> MOD: 32 <input type="checkbox"/> MOD: 33 <input type="checkbox"/> MOD: 34 <input type="checkbox"/> MOD: 35 <input type="checkbox"/> MOD: 38 <input type="checkbox"/>	Glass thickness 8 mm <input type="checkbox"/> 8,76 mm <input type="checkbox"/> 10 mm <input type="checkbox"/> 10,76 mm <input type="checkbox"/> 11,52 mm <input type="checkbox"/> 12 mm <input type="checkbox"/> 15 mm <input type="checkbox"/>	 	
		Glass clamps L=980 mm <input type="checkbox"/> L=1060 mm <input type="checkbox"/> or L: _____ mm L1: _____ mm L2: _____ mm L3: _____ mm L4: _____ mm	Glass clamp MOD: 30 <input type="checkbox"/> MOD: 31 <input type="checkbox"/> MOD: 32 <input type="checkbox"/> MOD: 33 <input type="checkbox"/> MOD: 34 <input type="checkbox"/> MOD: 35 <input type="checkbox"/> MOD: 38 <input type="checkbox"/>	Glass thickness 8 mm <input type="checkbox"/> 8,76 mm <input type="checkbox"/> 10 mm <input type="checkbox"/> 10,76 mm <input type="checkbox"/> 11,52 mm <input type="checkbox"/> 12 mm <input type="checkbox"/> 15 mm <input type="checkbox"/>	
		Crossbar holders L=980 mm <input type="checkbox"/> L=1060 mm <input type="checkbox"/> or L: _____ mm L1: _____ mm L2: _____ mm	<input type="checkbox"/> Holes per post 12 mm Infill bar <input type="checkbox"/> 16 mm Infill bar <input type="checkbox"/>		
		Wire-tec cable system L=980 mm <input type="checkbox"/> L=1060 mm <input type="checkbox"/> or L: _____ mm L1: _____ mm L2: _____ mm	<input type="checkbox"/> Eye bolts per post 3,2 mm Wire <input type="checkbox"/> 6,0 mm Wire <input type="checkbox"/>		

Sender

Name: _____

Company: _____

Tel: _____

Street: _____

Fax: _____

Town: _____

Email: _____

Postcode: _____

Base

MOD: 1000
 MOD: 1010
 MOD: 1020
 MOD: 1030

Specials form

Ø 42,4 x 2,0 mm
 Ø 42,4 x 2,6 mm
 Ø 48,3 x 2,0 mm
 Ø 48,3 x 2,6 mm

F
Grade

304
 316

See page 28

Type
Quantity

Type	See page 28	Quantity
<p>Glass clamps</p> <p>L: _____ mm L1: _____ mm L2: _____ mm</p>	<p>Glass clamp</p> <p>Glass thickness</p> <p>MOD: 30 <input type="checkbox"/> 8 mm <input type="checkbox"/> MOD: 31 <input type="checkbox"/> 8,76 mm <input type="checkbox"/> MOD: 32 <input type="checkbox"/> 10 mm <input type="checkbox"/> MOD: 33 <input type="checkbox"/> 10,76 mm <input type="checkbox"/> MOD: 34 <input type="checkbox"/> 11,52 mm <input type="checkbox"/> MOD: 35 <input type="checkbox"/> 12 mm <input type="checkbox"/> MOD: 38 <input type="checkbox"/> 15 mm <input type="checkbox"/></p>	<p>R= _____ °</p>
<p>Glass clamps</p> <p>L=980 mm <input type="checkbox"/> L=1060 mm <input type="checkbox"/></p> <p>or</p> <p>L: _____ mm L1: _____ mm L2: _____ mm L3: _____ mm L4: _____ mm</p>	<p>Glass clamp</p> <p>Glass thickness</p> <p>MOD: 30 <input type="checkbox"/> 8 mm <input type="checkbox"/> MOD: 31 <input type="checkbox"/> 8,76 mm <input type="checkbox"/> MOD: 32 <input type="checkbox"/> 10 mm <input type="checkbox"/> MOD: 33 <input type="checkbox"/> 10,76 mm <input type="checkbox"/> MOD: 34 <input type="checkbox"/> 11,52 mm <input type="checkbox"/> MOD: 35 <input type="checkbox"/> 12 mm <input type="checkbox"/> MOD: 38 <input type="checkbox"/> 15 mm <input type="checkbox"/></p>	<p>R= _____ °</p>
<p>Crossbar holders</p> <p>L: _____ mm L1: _____ mm L2: _____ mm</p>	<p><input type="checkbox"/> Holes per post</p> <p>12 mm Infill bar <input type="checkbox"/> 16 mm Infill bar <input type="checkbox"/></p>	<p>R= _____ °</p>
<p>Wire-tec cable system</p> <p>L: _____ mm L1: _____ mm L2: _____ mm</p>	<p><input type="checkbox"/> Eye bolts per post</p> <p>3,2 mm Wire <input type="checkbox"/> 6,0 mm Wire <input type="checkbox"/></p>	<p>R= _____ °</p>

Sender

Name: _____
 Tel: _____
 Fax: _____
 Email: _____

Company: _____
 Street: _____
 Town: _____
 Postcode: _____

Ø 42,4 x 2,6 mm
 Ø 48,3 x 2,6 mm

304
 316

Type				Quantity
	Glass clamps	Glass clamp	Glass thickness	
	L=980 mm <input type="checkbox"/> L=1060 mm <input type="checkbox"/> or L: _____ mm	MOD: 30 <input type="checkbox"/> MOD: 31 <input type="checkbox"/> MOD: 32 <input type="checkbox"/> MOD: 33 <input type="checkbox"/> MOD: 34 <input type="checkbox"/> MOD: 35 <input type="checkbox"/> MOD: 38 <input type="checkbox"/>	8 mm <input type="checkbox"/> 8,76 mm <input type="checkbox"/> 10 mm <input type="checkbox"/> 10,76 mm <input type="checkbox"/> 11.52 mm <input type="checkbox"/> 12 mm <input type="checkbox"/> 15 mm <input type="checkbox"/>	
	L1: _____ mm			
	L2: _____ mm			
	Glass clamps	Glass clamp	Glass thickness	
	L=980 mm <input type="checkbox"/> L=1060 mm <input type="checkbox"/> or L: _____ mm	MOD: 30 <input type="checkbox"/> MOD: 31 <input type="checkbox"/> MOD: 32 <input type="checkbox"/> MOD: 33 <input type="checkbox"/> MOD: 34 <input type="checkbox"/> MOD: 35 <input type="checkbox"/> MOD: 38 <input type="checkbox"/>	8 mm <input type="checkbox"/> 8,76 mm <input type="checkbox"/> 10 mm <input type="checkbox"/> 10,76 mm <input type="checkbox"/> 11.52 mm <input type="checkbox"/> 12 mm <input type="checkbox"/> 15 mm <input type="checkbox"/>	
	L1: _____ mm			
	L2: _____ mm			
	L3: _____ mm			
	L4: _____ mm			
	Crossbar holders	<input type="checkbox"/> Holes per post		
	L=980 mm <input type="checkbox"/> L=1060 mm <input type="checkbox"/> or L: _____ mm			
	L1: _____ mm	12 mm Infill bar <input type="checkbox"/> 16 mm Infill bar <input type="checkbox"/>		
	L2: _____ mm			
	Wire-tec cable system	<input type="checkbox"/> Eye bolts per post		
	L=980 mm <input type="checkbox"/> L=1060 mm <input type="checkbox"/> or L: _____ mm			
	L1: _____ mm	3,2 mm Wire <input type="checkbox"/> 6,0 mm Wire <input type="checkbox"/>		
	L2: _____ mm			

Sender

Name: _____
 Tel: _____
 Fax: _____
 Email: _____

Company: _____
 Street: _____
 Town: _____
 Postcode: _____

UK Distributor of

ONLEVE
BALUSTRADES

and

posiglaze
frameless balustrade

Introducing...

Glass-tec
PRODUCT BROCHURE

Fastec Handrail Systems Ltd are delighted to launch our new revolutionary Glass-tec product brochure which showcases our new range of structural glass base profiles and accessories. With 14 different choices of base fixing systems available we have brought together a complete solution for all your project requirements all of which are stylish, safe and easy to assemble.



Glass-tec
PRODUCT BROCHURE

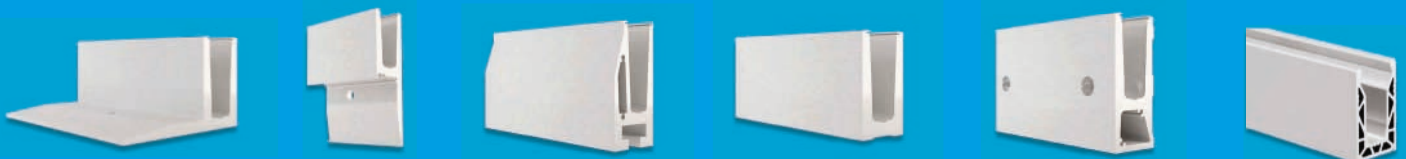

Innovative Handrail Solutions

driven by quality

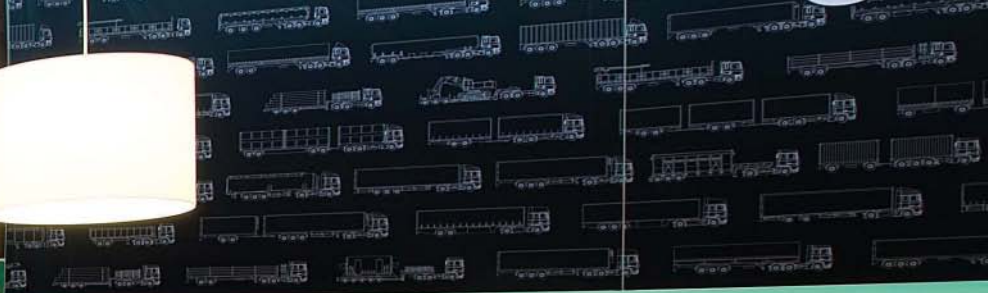

Fahrertraining



To request a copy of the new brochure contact your local sales team



Flex-Fit



Introducing 'Flex-fit' which is the new revolutionary glass fixing system. Flex-fit allows perfect alignment of glass with just a simple sliding movement you can position the glass with precision allowing for up to 40mm movement helping to reduce installation times by up to 30%..

Adjust the way you work





SAFETY TESTING

safety first

Has your balustrade been tested to **BS 6180** 'Barriers in and about buildings'?

Fastec has established the needs of our customers and has recognised that most handrail systems on the market today have not been tested to ensure they meet British Standard side loading criteria.

the **fastec** response

For your absolute peace of mind, and to create confidence in your installation for you and your customer we have commissioned extensive testing by independent engineers to establish exactly which design, tube size and thickness, upright centres and fittings will be safest for your installation.

The test results show actual 'as installed' results. Please see the following tables for guidance

Full test report and
Test Certificates available
to download from
www.fastechandrails.co.uk





test results

System 1 - Side Mounted Balustrade Testing in accordance with BS 6180

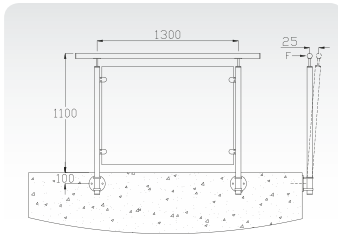

SYSTEM 1 – 42.4mm DIAMETER TUBE		
		Fastec Code
S/S Baluster Tube Diameter (mm)	42.4x2.6	341900.426.S
S/S Hand Rail Diameter (mm)	42.4x2.0	341900.422.S
Handrail Height (mm)	1100	
Baluster Post Spacing (mm)	1300	
Mounting Type	Side Bracket	341010.420.S
No. of Fixing Bolts Per Post	2	M12
Handrail Connection	Stem	34.0110.426.S
Infill Type	Glass Panel	10mm
Glass Clamps	4 Per Panel	34.3210.420.S
DEFLECTION BEYOND ALLOWABLE LIMIT OCCURRED AT A LOAD OF 1.9KN/m		

BS 6180: Table 2		
LOAD (KN/m)	CATEGORY	PASSED
0.22	B&E (iii)	✓
0.36	A (i), B&E (iv)	✓
0.74	A (ii), B&E (v), C3 (viii), (ix)	✓
1.5	C (vi), C1/C2 (vii), C5 (x), D (xiii), F/G (xiv), F/G (xv)	✓
3.0	C5 (x), (X)	X

SYSTEM 1 - 48.3mm DIAMETER TUBE		
		Fastec Code
S/S Baluster Tube Diameter (mm)	48.3x2.6	341900.486.S
S/S Hand Rail Diameter (mm)	48.3x2.0	341900.242.S
Handrail Height (mm)	1100	
Baluster Post Spacing (mm)	1300	
Mounting Type	Side Bracket	341010.480.S
No. of Fixing Bolts Per Post	2	M12
Handrail Connection	Stem	34.0110.486.S
Infill Type	Glass Panel	10mm
Glass Clamps	4 Per Panel	34.3210.480.S
DEFLECTION BEYOND ALLOWABLE LIMIT OCCURRED AT A LOAD OF 2.0KN/m		

System 2, 3, 4 - Surface Mounted Balustrade Testing in accordance with BS 6180

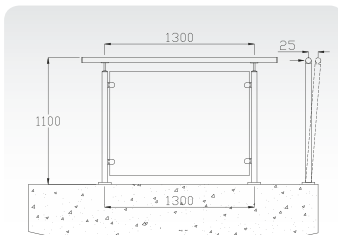

SYSTEM 2 – 42.4mm DIAMETER TUBE		
		Fastec Code
S/S Baluster Tube Diameter (mm)	42.4x2.6	341900.426.S
S/S Hand Rail Diameter (mm)	42.4x2.0	341900.422.S
Handrail Height (mm)	1100	
Baluster Post Spacing (mm)	1300	
Mounting Type	Flange Base	34.1100.420.R
No. of Fixing Bolts Per Post	3	M10
Handrail Connection	Stem	34.0110.426.S
Infill Type	Glass Panel	10mm
Glass Clamps	4 Per Panel	34.3210.420.S
DEFLECTION BEYOND ALLOWABLE LIMIT OCCURRED AT A LOAD OF 2.25KN/m		

SYSTEM 3 – 42.4mm DIAMETER TUBE		
		Fastec Code
S/S Baluster Tube Diameter (mm)	42.4x2.6	131900.426.S
S/S Hand Rail Diameter (mm)	42.4x2.0	131900.422.S
Handrail Height (mm)	1100	
Baluster Post Spacing (mm)	1300	
Mounting Type	Flange Base	34.1110.420.R
No. of Fixing Bolts Per Post	2	M10
Handrail Connection	Stem	34.0110.426.S
Infill Type	Glass Panel	10mm
Glass Clamps	4 Per Panel	34.3210.420.S
DEFLECTION BEYOND ALLOWABLE LIMIT OCCURRED AT A LOAD OF 1.9KN/m		

SYSTEM 4 – 42.4mm DIAMETER TUBE		
		Fastec Code
S/S Baluster Tube Diameter (mm)	42.4x2.6	341900.426.S
S/S Hand Rail Diameter (mm)	42.4x2.0	341900.422.S
Handrail Height (mm)	1100	
Baluster Post Spacing (mm)	1300	
Mounting Type	Flange Base	34.1120.420.R
No. of Fixing Bolts Per Post	2	M10
Handrail Connection	Stem	34.0110.426.S
Infill Type	Glass Panel	10mm
Glass Clamps	4 Per Panel	34.3210.420.S
DEFLECTION BEYOND ALLOWABLE LIMIT OCCURRED AT A LOAD OF 2.05KN/m		

BS 6180: Table 2		
LOAD (KN/m)	CATEGORY	PASSED
0.22	B&E (iii)	✓
0.36	A (i), B&E (iv)	✓
0.74	A (ii), B&E (v), C3 (viii), (ix)	✓
1.5	C (vi), C1/C2 (vii), C5 (x), D (xiii), F/G (xiv), F/G (xv)	✓
3.0	C5 (x), (X)	X

SYSTEM 2 – 48.3mm DIAMETER TUBE		
		Fastec Code
S/S Baluster Tube Diameter (mm)	48.3x2.6	341900.486.S
S/S Hand Rail Diameter (mm)	48.3x2.0	341900.482.S
Handrail Height (mm)	1100	
Baluster Post Spacing (mm)	1300	
Mounting Type	Flange Base	34.1100.480.R
No. of Fixing Bolts Per Post	3	M10
Handrail Connection	Stem	34.0110.486.S
Infill Type	Glass Panel	10mm
Glass Clamps	4 Per Panel	34.3210.480.S
DEFLECTION BEYOND ALLOWABLE LIMIT OCCURRED AT A LOAD OF 2.4KN/m		

SYSTEM 3 – 48.3mm DIAMETER TUBE		
		Fastec Code
S/S Baluster Tube Diameter (mm)	48.3x2.6	131900.486.S
S/S Hand Rail Diameter (mm)	48.3x2.0	131900.482.S
Handrail Height (mm)	1100	
Baluster Post Spacing (mm)	1300	
Mounting Type	Flange Base	34.1110.420.R
No. of Fixing Bolts Per Post	2	M10
Handrail Connection	Stem	34.0110.486.S
Infill Type	Glass Panel	10mm
Glass Clamps	4 Per Panel	34.3210.480.S
DEFLECTION BEYOND ALLOWABLE LIMIT OCCURRED AT A LOAD OF 2.2KN/m		

SYSTEM 4 – 48.3mm DIAMETER TUBE		
		Fastec Code
S/S Baluster Tube Diameter (mm)	48.3x2.6	341900.486.S
S/S Hand Rail Diameter (mm)	48.3x2.0	341900.482.S
Handrail Height (mm)	1100	
Baluster Post Spacing (mm)	1300	
Mounting Type	Flange Base	34.1120.480.R
No. of Fixing Bolts Per Post	2	M10
Handrail Connection	Stem	34.0110.486.S
Infill Type	Glass Panel	10mm
Glass Clamps	4 Per Panel	34.3210.480.S
DEFLECTION BEYOND ALLOWABLE LIMIT OCCURRED AT A LOAD OF 2.3KN/m		

System 5 - Surface Mounted Balustrade Testing in accordance with BS 6180

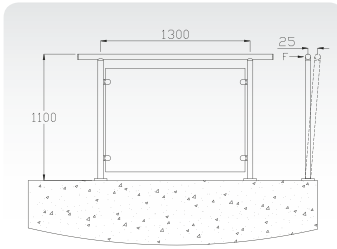

SYSTEM 5 – 42.4mm DIAMETER TUBE

		Fastec Code
S/S Baluster Tube Diameter (mm)	42.4x2.6	341900.426.S
S/S Hand Rail Diameter (mm)	42.4x2.0	341900.422.S
Handrail Height (mm)	1100	
Baluster Post Spacing (mm)	1300	
Mounting Type	Flange Base	341100.420.R
No. of Fixing Bolts Per Post	3	M10
Handrail Connection	Connector	34.0731.426.S
Infill Type	Glass Panel	10mm
Glass Clamps	4 Per Panel	34.3210.420.S
DEFLECTION BEYOND ALLOWABLE LIMIT OCCURRED AT A LOAD OF 2.0KN/m		

BS 6180: Table 2

LOAD (KN/m)	CATEGORY	PASSED
0.22	B&E (ii)	✓
0.36	A (i), B&E (iv)	✓
0.74	A (ii), B&E (v), C3 (viii), (ix)	✓
15	C (vi), C1/C2 (vii), C5 (x), D (xiii), F/G (xiv), F/G (xv)	✓
3.0	C5 (x), (xi)	X

SYSTEM 5 – 48.3mm DIAMETER TUBE

		Fastec Code
S/S Baluster Tube Diameter (mm)	48.3x2.6	341900.486.S
S/S Hand Rail Diameter (mm)	48.3x2.0	341900.482.S
Handrail Height (mm)	1100	
Baluster Post Spacing (mm)	1300	
Mounting Type	Flange Base	341100.480.R
No. of Fixing Bolts Per Post	3	M10
Handrail Connection	Clued Connector	34.0731.486.S
Infill Type	Glass Panel	10mm
Glass Clamps	4 Per Panel	34.3210.480.S
DEFLECTION BEYOND ALLOWABLE LIMIT OCCURRED AT A LOAD OF 2.25KN/m		

System 6 - Surface Mounted Balustrade Testing in accordance with BS 6180

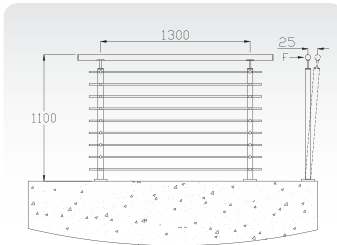

SYSTEM 6 – 42.4mm DIAMETER TUBE

		Fastec Code
S/S Baluster Tube Diameter (mm)	42.4x2.6	341900.426.S
S/S Hand Rail Diameter (mm)	42.4x2.0	341900.422.S
Handrail Height (mm)	1100	
Baluster Post Spacing (mm)	1300	
Mounting Type	Flange Base	341100.420.R
No. of Fixing Bolts Per Post	3	M10
Handrail Connection	Stem	34.0110.426.S
Infill Type	12mm Bars	341900.012.S
Cross Bar Holders	9 Per Post	34.3312.420.S
DEFLECTION BEYOND ALLOWABLE LIMIT OCCURRED AT A LOAD OF 2.25KN/m		

BS 6180: Table 2

LOAD (KN/m)	CATEGORY	PASSED
0.22	B&E (ii)	✓
0.36	A (i), B&E (iv)	✓
0.74	A (ii), B&E (v), C3 (viii), (ix)	✓
15	C (vi), C1/C2 (vii), C5 (x), D (xiii), F/G (xiv), F/G (xv)	✓
3.0	C5 (x), (xi)	X

SYSTEM 6 – 48.3mm DIAMETER TUBE

		Fastec Code
S/S Baluster Tube Diameter (mm)	48.3x2.6	341900.486.S
S/S Hand Rail Diameter (mm)	48.3x2.0	341900.482.S
Handrail Height (mm)	1100	
Baluster Post Spacing (mm)	1300	
Mounting Type	Flange Base	341100.480.R
No. of Fixing Bolts Per Post	3	M10
Handrail Connection	Stem	34.0110.486.S
Infill Type	12mm Bars	341900.012.S
Cross Bar Holders	9 Per Post	34.3312.480.S
DEFLECTION BEYOND ALLOWABLE LIMIT OCCURRED AT A LOAD OF 2.2KN/m		

System 7 - Clamp Fix Balustrade Testing in accordance with BS 6180

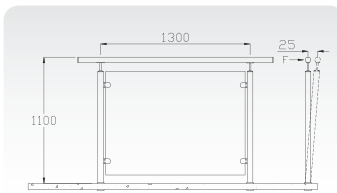

SYSTEM 7 – 42.4mm DIAMETER TUBE

		Fastec Code
S/S Baluster Tube Diameter (mm)	42.4x2.6	341900.426.S
S/S Hand Rail Diameter (mm)	42.4x2.0	341900.422.S
Handrail Height (mm)	1100	
Baluster Post Spacing (mm)	1300	
Mounting Type	Clamp Fix	341310.420.S
No. of Fixing Bolts Per Post	1	M12
Handrail Connection	Stem	34.0110.426.S
Infill Type	Glass Panel	10mm
Glass Clamps	4 Per Panel	34.3210.420.S
DEFLECTION BEYOND ALLOWABLE LIMIT OCCURRED AT A LOAD OF 1.4KN/m		

BS 6180: Table 2

LOAD (KN/m)	CATEGORY	PASSED
0.22	B&E (ii)	✓
0.36	A (i), B&E (iv)	✓
0.74	A (ii), B&E (v), C3 (viii), (ix)	✓
15	C (vi), C1/C2 (vii), C5 (x), D (xiii), F/G (xiv), F/G (xv)	X/✓
3.0	C5 (x), (xi)	X

SYSTEM 7 – 48.3mm DIAMETER TUBE

		Fastec Code
S/S Baluster Tube Diameter (mm)	48.3x2.6	341900.486.S
S/S Hand Rail Diameter (mm)	48.3x2.0	341900.482.S
Handrail Height (mm)	1100	
Baluster Post Spacing (mm)	1300	
Mounting Type	Clamp Fix	341310.480.S
No. of Fixing Bolts Per Post	1	M12
Handrail Connection	Stem	34.0110.486.S
Infill Type	Glass Panel	10mm
Glass Clamps	4 Per Panel	34.3210.480.S
DEFLECTION BEYOND ALLOWABLE LIMIT OCCURRED AT A LOAD OF 1.55KN/m		





CARE AND MAINTENANCE

care and maintenance

To gain the maximum benefits from the Fastec range, the correct care and maintenance procedures should be followed during and after installation.

To achieve maximum corrosion resistance and appearance, the surface of the stainless steel must be kept clean; this is extremely important when used in an external environment.

It is necessary to clean your installation immediately after fitting is complete using Fastec Stain Remover. Following this, periodical cleaning with Fastec Stainless Steel Cleaner will help form a protective barrier against the atmosphere.

Installations in an external environment will require a cleaning schedule to be followed, this is a periodic cleaning off approximately every 3-6/6-12 months thereafter.

For installations in **aggressive environments**, for example coastal regions and swimming pools, you will need to take particular care with cleaning and maintenance to inhibit corrosion. The cleaning schedules relating to these types of areas are much more frequent than standard external installations. In addition, we strongly recommend that only mirror polished items are installed in such environments due to their higher corrosion resistant finish.

cleaning methods

To assist with care and maintenance we provide Fastec Stainless Steel Cleaner and Fastec Stain Remover.

Fastec Stainless Steel Cleaner is a general purpose stainless steel cleansing spray. It can be used in conjunction with Fastec Stain Remover or as a cleaning product in its own right to clean and shine stainless steel.

Fastec Stain Remover is an acid based cleaner which temporarily strips the stainless steel of its passive layer so any contaminants can be removed. It should then be washed off with water which neutralises the acid and causes the passive layer to regenerate on the surface of the stainless steel. This surface should be periodically protected with Fastec Stainless Steel Cleaner.

↪ Hints and tips

Always clean your installation once it has been completed. This is necessary to remove any contaminants on the surface of the material to prevent future problems and leaves a finished look behind for your customer.

For outstanding results, use Fastec Stainless Steel Cleaner for internal installations and Fastec Stain Remover followed by Fastec Stainless Steel Cleaner for external applications.

Always use a lint-free cloth, never use an abrasive cleaner or cloth.

It is important to remember that masonry and brick cleaners contain acid, so protect any stainless steel surfaces during their use. Any splashes should be washed off straight away with water.

► **Further information on cleaning schedules and maintenance can be found on our website.**



index

Fittings

MOD: 0100	Stem Connector	Page 16
MOD: 0105	Stem Connector - Adjustable	Page 16
MOD: 0110	Stem Connector	Page 16
MOD: 0111	Stem Connector	Page 16
MOD: 0115	Stem Connector - Adjustable	Page 16
MOD: 0116	Stem Connector	Page 16
MOD: 0120	Stem Connector - 135°	Page 17
MOD: 0121	Stem Connector - 135°	Page 17
MOD: 0130	Stem Connector - 90°	Page 17
MOD: 0131	Stem Connector - 90°	Page 17
MOD: 0200	Stem Connector	Page 18
MOD: 0205	Stem Connector - Adjustable	Page 18
MOD: 0210	Stem Connector - 135°	Page 18
MOD: 0220	Stem Connector - 90°	Page 18
MOD: 0300	Handrail Saddle	Page 19
MOD: 0310	Stem	Page 19
MOD: 0315	Stem - Adjustable	Page 19
MOD: 0400	Handrail Bracket - Post Fix	Page 20
MOD: 0405	Handrail Bracket - Post Fix	Page 20
MOD: 0410	Handrail Bracket - Post Fix	Page 21
MOD: 0415	Handrail Bracket - Post Fix	Page 21
MOD: 0420	Handrail Bracket - Post Fix	Page 21
MOD: 0425	Handrail Bracket - Post Fix	Page 21
MOD: 0426	Handrail Bracket - Post Fix	Page 21
MOD: 0430	Handrail Bracket - Wall Fix	Page 22
MOD: 0435	Handrail Bracket - Wall Fix	Page 22
MOD: 0440	Handrail Bracket - Glass Fix	Page 23
MOD: 0445	Handrail Bracket - Glass Fix	Page 23
MOD: 0510	Handrail Bracket - Wall Fix	Page 24
MOD: 0511	Handrail Bracket - Wall Fix	Page 24
MOD: 0520	Handrail Bracket - Wall Fix	Page 24
MOD: 0521	Handrail Bracket - Wall Fix	Page 24
MOD: 0530	Handrail Support	Page 25
MOD: 0540	Wall Rosette	Page 25
MOD: 0541	Stem Connector	Page 25
MOD: 0542	Rosette Cover	Page 25
MOD: 0600	Elbow	Page 26
MOD: 0610	Elbow	Page 26
MOD: 0620	Elbow	Page 26
MOD: 0630	Elbow	Page 26



Fittings (continued)

MOD: 0640	Elbow - Adjustable	Page 27
MOD: 0650	Elbow - Weldable	Page 27
MOD: 0660	Return End	Page 28
MOD: 0710	Tee Connector	Page 28
MOD: 0720	Connector	Page 28
MOD: 0730	Connector	Page 29
MOD: 0731	Connector	Page 29
MOD: 0740	Wall Flange	Page 29
MOD: 0750	End Ball	Page 29
MOD: 0760	Connector	Page 29
MOD: 0800	End Cap - Flat - Hit In	Page 30
MOD: 0801	End Cap - Flat - Hit In	Page 30
MOD: 0810	End Cap - Radiused - Hit In	Page 30
MOD: 0811	End Cap - Radiused - Hit In	Page 30
MOD: 0820	End Cap - Domed - Hit In	Page 31
MOD: 0850	End Cap - Flat	Page 31
MOD: 0860	End Cap - Radiused	Page 31
MOD: 0870	End Cap - Flat - Weldable	Page 31
MOD: 1000	Side Fix Bracket	Page 32
MOD: 1010	Side Fix Bracket	Page 32
MOD: 1020	Side Fix Bracket	Page 32
MOD: 1030	Side Fix Bracket	Page 32
MOD: 1040	Side Fix Bracket	Page 32
MOD: 1100	Welded Base	Page 33
MOD: 1101	Base Cover	Page 33
MOD: 1110	Welded Base	Page 34
MOD: 1111	Base Cover	Page 34
MOD: 1120	Welded Base	Page 34
MOD: 1121	Base Cover	Page 34
MOD: 1200	Welded Base	Page 35
MOD: 1210	Welded Base	Page 35
MOD: 1250	Welded Base	Page 35
MOD: 1280	Welded Base	Page 35
MOD: 1300	Welded Insert	Page 36
MOD: 1310	Inner Flange	Page 36
MOD: 1311	Inner Flange Washer	Page 36
MOD: 1320	Outer Flange	Page 36
MOD: 1321	Outer Flange Washer	Page 36
MOD: 1510	Baluster Post	Page 33
MOD: 1520	Baluster Post	Page 34
MOD: 1530	Baluster Post	Page 34
MOD: 1610	Baluster Post	Page 33
MOD: 1620	Baluster Post	Page 33
MOD: 1630	Baluster Post	Page 33
MOD: 1710	Baluster Post	Page 36
MOD: 2010	Crossbar Holder	Page 37
MOD: 2012	Crossbar Holder	Page 37
MOD: 2212	Crossbar Holder	Page 37, 38
MOD: 2312	Crossbar Holder	Page 37, 38
MOD: 2416	Crossbar Holder	Page 38
MOD: 2812	Inline Crossbar Holder	Page 38
MOD: 2912	Inline Crossbar Holder - Adjustable	Page 38

Tubes & Bars

MOD: 1900	Tubes & Bars	Page 40
MOD: 1910	Tubes & Bars	Page 40

Mirror Polished

MOD: 0110	Stem Connector	Page 42
MOD: 0115	Stem Connector - Adjustable	Page 42
MOD: 0130	Stem Connector - 90°	Page 42
MOD: 0440	Handrail Bracket - Glass Fix	Page 42
MOD: 0445	Handrail Bracket - Glass Fix	Page 42
MOD: 0521	Handrail Bracket - Wall Fix	Page 42
MOD: 0610	Elbow	Page 43
MOD: 0640	Elbow - Adjustable	Page 43
MOD: 0720	Connector	Page 43
MOD: 0731	Connector	Page 43
MOD: 0740	Wall Flange	Page 43
MOD: 0860	End Cap	Page 43
MOD: 1010	Side Fix Bracket	Page 44
MOD: 1101	Base Cover	Page 44
MOD: 1510	Baluster Post	Page 44
MOD: 1900	Tubes & Bars	Page 44
MOD: 1910	Tubes & Bars	Page 44
MOD: 32	Glass Clamp - Model 32	Page 44, 49

Glass Clamps

MOD: 30	Glass Clamp - Model 30	Page 46
MOD: 31	Glass Clamp - Model 31	Page 47
MOD: 32	Glass Clamp - Model 32	Page 48, 49
MOD: 32.100	Glass Clamp - Model 32	Page 50
MOD: 32.200	Glass Clamp - Model 32	Page 50
MOD: 33.100	Glass Clamp - Model 33	Page 50
MOD: 33.200	Glass Clamp - Model 33	Page 50
MOD: 33	Glass Clamp - Model 33	Page 51
MOD: 34	Glass Clamp - Model 34	Page 52
MOD: 35	Glass Clamp - Model 35	Page 53
MOD: 38	Glass Clamp - Model 38	Page 54
Glass Clamp Rubbers	Glass Clamp Rubbers	Page 55, 56
Glass Clamp Pins	Glass Clamp Security Pins	Page 56
Cover Caps	Glass Clamp Cover Caps	Page 56

Glass Connectors & Panel Holders

MOD: 4010	Glass Connector	Page 58
MOD: 4020	Glass Connector	Page 58
MOD: 4030	Glass Connector	Page 59
MOD: 4500	Panel Holder	Page 60
MOD: 4510	Panel Holder	Page 60

Wire-tec

MOD: 6000	Tensioner	Page 62
MOD: 6010	Terminal	Page 62
MOD: 6020	Eye Bolt	Page 62
MOD: 6030	Cable Stopper	Page 62
MOD: 6100	Tensioner	Page 64
MOD: 6110	Crossbar Holder	Page 64
MOD: 6120	Crossbar Holder	Page 64
MOD: 6130	Crossbar Holder	Page 64
MOD: 6203	Wire 3.2mm	Page 62, 64
MOD: 6206	Wire 6.0mm	Page 62, 64
MOD: 6350	Cable Cutter	Page 62

Timber-tec

MOD: 6400	Alignment Tool	Page 67
MOD: 8000	Handrail	Page 66
MOD: 8010	Elbow	Page 66
MOD: 8020	Elbow - Adjustable	Page 66
MOD: 8030	Return End	Page 67
MOD: 8040	End Cap	Page 67
MOD: 8050	Connector	Page 67
MOD: 8060	Adaptor	Page 67

Accessories

MOD: 9010	Glue	Page 69
MOD: 9020	Internal Cleaner	Page 69
MOD: 9025	Glass Cleaner	Page 69
MOD: 9030	External Cleaner	Page 69
MOD: 9027	Cleaner Kit	Page 69
MOD: 9100	Bolt	Page 70
MOD: 9101	Bolt	Page 70
MOD: 9110	Bolt	Page 70
MOD: 9120	Bolt	Page 70
MOD: 9160	Dual Head Screw	Page 71
MOD: 9165	Coach Screw	Page 71
MOD: 9170	Screw	Page 71
MOD: 9180	Threaded Insert	Page 59, 71
MOD: 9200	'C' Spanner	Page 69
MOD: 9300	Allen Key Set	Page 69

information



Delivery

Fastec dispatch all orders via carrier on a next day service.

Orders must be received before 2.00pm to be dispatched same day.

Upgraded timed delivery services are available (ie. before noon, before 10.30am, Saturday am) at an additional cost.

Off-shore and some Scottish Highlands locations are only available on a 2-3 day service.



Price /Payment

All prices quoted are net, VAT will be added.

Delivery charges are in addition to the fitting prices and will be stated at time of quoting/ordering.

Accounts not settled within the agreed time period will be placed on stop and no further goods will be dispatched until the overdue monies are settled.



Returns

Goods will only be accepted if they are received in a resaleable condition and in their original packaging.

Notification of a return must be made in writing in the first instance and must be received within 1 month after receipt.

A handling fee will be charged, the amount will be confirmed after a notification has been received.

Collection of the items for return can be arranged by Fastec via our carrier but will incur an additional charge. Please state if you require a collection arranging at time of notification. A cost will then be confirmed.



Claims

Notice of any claim relating to shortages or damaged goods shall be made to the company in writing within 48 hours of receipt of goods. In the event of loss or non-delivery of the goods the customer shall notify the company in writing within 3 days of receiving the advice note.

All goods received damaged on delivery must be signed for as 'Damaged', claims for goods received as damaged but signed for as 'Received in good condition' will not be accepted.

Quantities must be checked on delivery before signing as accepted.

↳ Terms & Conditions

We reserve the right to change any products within this brochure relating to the design and measurements without prior warning.

Products may be updated or revised and actual products may be slightly different to the items illustrated.

Different shapes and product types may have slightly different polishing matches due to the techniques and processes used.

We cannot be held responsible for printing errors.

The company shall not be responsible for any expenditure losses. Any compensation is limited to the value of the goods.

► **Our full terms & conditions are available on request.**



Version 2016-07-001



Fastec Handrail Systems Limited

Barrett House, Cutler Heights Lane
Bradford, West Yorkshire, BD4 9HU
Tel: 01274 474330
Fax: 01274 474361
Email: sales@fastechandrails.co.uk